



## **DNPM**

**ProLinX Gateway**

DNP 3.0 Master

November 13, 2020

## Important Installation Instructions

Power, Input, and Output (I/O) wiring must be in accordance with Class I, Division 2 wiring methods, Article 501-4 (b) of the National Electrical Code, NFPA 70 for installation in the U.S., or as specified in Section 18-1J2 of the Canadian Electrical Code for installations in Canada, and in accordance with the authority having jurisdiction. The following warnings must be heeded:

- A** WARNING - EXPLOSION HAZARD - SUBSTITUTION OF COMPONENTS MAY IMPAIR SUITABILITY FOR CLASS I, DIV. 2;
- B** WARNING - EXPLOSION HAZARD - WHEN IN HAZARDOUS LOCATIONS, TURN OFF POWER BEFORE REPLACING OR WIRING MODULES
- C** WARNING - EXPLOSION HAZARD - DO NOT DISCONNECT EQUIPMENT UNLESS POWER HAS BEEN SWITCHED OFF OR THE AREA IS KNOWN TO BE NONHAZARDOUS.
- D** THIS DEVICE SHALL BE POWERED BY CLASS 2 OUTPUTS ONLY.

### All ProLinx® Products

WARNING – EXPLOSION HAZARD – DO NOT DISCONNECT EQUIPMENT UNLESS POWER HAS BEEN SWITCHED OFF OR THE AREA IS KNOWN TO BE NON-HAZARDOUS.

AVERTISSEMENT – RISQUE D'EXPLOSION – AVANT DE DÉCONNECTER L'EQUIPMENT, COUPER LE COURANT OU S'ASSURER QUE L'EMPLACEMENT EST DÉSIGNÉ NON DANGEREUX.

### Markings

UL/cUL	ISA 12.12.01 Class I, Div 2 Groups A, B, C, D
cUL	C22.2 No. 213-M1987



CL I Div 2 GPs A, B, C, D

Temp Code T5

II 3 G

Ex nA nL IIC T5 X

0° C ≤ Ta ≤ 60° C

II – Equipment intended for above ground use (not for use in mines).

3 – Category 3 equipment, investigated for normal operation only.

G – Equipment protected against explosive gasses.

### ProLinx Gateways with Ethernet Ports

Series C ProLinx™ Gateways with Ethernet ports do **NOT** include the HTML Web Server. The HTML Web Server must be ordered as an option. This option requires a factory-installed hardware addition. The HTML Web Server now supports:

- 8 MB file storage for HTML files and associated graphics files (previously limited to 384K)
- 32K maximum HTML page size (previously limited to 16K)

### To upgrade a previously purchased Series C model:

Contact your ProSoft Technology distributor to order the upgrade and obtain a Returned Merchandise Authorization (RMA) to return the unit to ProSoft Technology.

## ***To Order a ProLinX Plus gateway with the -WEB option:***

Add **-WEB** to the standard ProLinX part number. For example, **5201-MNET-MCM-WEB**.

## **Your Feedback Please**

We always want you to feel that you made the right decision to use our products. If you have suggestions, comments, compliments or complaints about the product, documentation, or support, please write or call us.

### **ProSoft Technology, Inc.**

+1 (661) 716-5100

+1 (661) 716-5101 (Fax)

[www.prosoft-technology.com](http://www.prosoft-technology.com)

[support@prosoft-technology.com](mailto:support@prosoft-technology.com)

Copyright © ProSoft Technology, Inc. 2020. All Rights Reserved.

DNPM Driver Manual

ProSoft Technology<sup>®</sup>, ProLinX<sup>®</sup>, inRAx<sup>®</sup>, ProTalk<sup>®</sup>, and RadioLinX<sup>®</sup> are Registered Trademarks of ProSoft Technology, Inc. All other brand or product names are or may be trademarks of, and are used to identify products and services of, their respective owners.

## **ProSoft Technology<sup>®</sup> Product Documentation**

In an effort to conserve paper, ProSoft Technology no longer includes printed manuals with our product shipments. User Manuals, Datasheets, Sample Ladder Files, and Configuration Files are provided at:  
[www.prosoft-technology.com](http://www.prosoft-technology.com)

Printed documentation is available for purchase. Contact ProSoft Technology for pricing and availability.

North America: +1.661.716.5100

Asia Pacific: +603.7724.2080

Europe, Middle East, Africa: +33 (0) 5.3436.87.20

Latin America: +1.281.298.9109



# Contents

Important Installation Instructions .....	2
Your Feedback Please.....	3
ProSoft Technology® Product Documentation.....	3
<b>1 Functional Overview</b> .....	<b>7</b>
1.1 Module Internal Database .....	8
1.2 DNP Master Database Layout .....	8
1.3 DNP Master Driver Data Flow .....	9
<b>2 Port Physical and Protocol Specifications</b> .....	<b>11</b>
2.1 DNP 3.0 Master Port Specifications.....	11
2.2 Serial Port Specifications .....	11
<b>3 DNPM Protocol Configuration</b> .....	<b>13</b>
3.1 [DNP Master].....	13
3.2 [DNP Master Database] .....	14
3.3 [DNP Master Slave List] .....	15
3.4 [DNP Master Commands] .....	16
<b>4 Communication Port Cables</b> .....	<b>25</b>
4.1 DNP 3.0 Master Port .....	25
4.2 Port 0, 1, 2, 3: RS-232 - Null Modem (DTE with Hardware Handshaking) .....	26
4.3 Port 0, 1, 2, 3: RS-232 - Null Modem (DTE without Hardware Handshaking) .....	27
4.4 Port 0, 1, 2, 3: RS-232 - DTE to DCE Modem Connection .....	27
4.5 Collision Avoidance (DNP modules only).....	28
4.6 Port 0, 1, 2, 3: RS-422 Interface Connections .....	29
4.7 Port 0, 1, 2, 3: RS-485 Interface Connections .....	29
<b>5 LED Indicators</b> .....	<b>31</b>
5.1 Common module LEDs .....	31
5.2 LEDs for Port 0 Serial Port.....	32
5.3 4101 Series LEDs .....	32
<b>6 Reference</b> .....	<b>33</b>
6.1 Error Codes .....	33
6.2 Device Profile .....	37
6.3 Subset Definition .....	39
6.4 Command List Entry Form .....	45

---

<b>7</b>	<b>Support, Service &amp; Warranty</b>	<b>49</b>
7.1	How to Contact Us: Technical Support.....	49
7.2	Return Material Authorization (RMA) Policies and Conditions.....	50
7.3	LIMITED WARRANTY .....	51
<b>Index</b>		<b>55</b>

---

# 1 Functional Overview

## *In This Chapter*

- ❖ Module Internal Database ..... 8
- ❖ DNP Master Database Layout..... 8
- ❖ DNP Master Driver Data Flow ..... 9

The DNP 3.0 Master protocol driver exists in a single port (DNPM) implementation only. The DNPM port operates in a Master mode only, supporting the DNP 3.0 protocol in a Level 2 implementation.

The DNP Master driver is implemented in ProLinx communication modules to interface DNP slave units with a variety of communication protocols and interfaces. This driver supports DNP version 3.0, subset level 2. The Reference chapter of this documentation contains the Device Profile for the driver. The Reference chapter contains the subset definition for the driver. This document serves as the base for understanding the DNP Master driver functionality and configuration. The discussion is general in nature deferring specifics to the individual product documents.

Before attempting to use this or any other DNP protocol device, verify that you have a copy of the DNP Basic 4 document and other information available through the DNP User Group. It is very important that these documents be understood for successful application of the protocol in a user's solution. If you are a member of the user group, you can download these documents from the <http://www.dnp.org> (<http://www.dnp.org>) web site.

All data in the module's database configured as DNP data points is available to the remote devices for read and write requests. This permits other devices connected to the ProLinx unit to monitor and control DNP slave devices connected to the master port.

### 1.1 Module Internal Database

The internal database is central to the functionality of the module. This database is shared between all the ports on the module and is used as a conduit to pass information from one device on one network to one or more devices on another network. This permits data from devices on one communication port/network to be viewed and controlled by devices on another port/network.

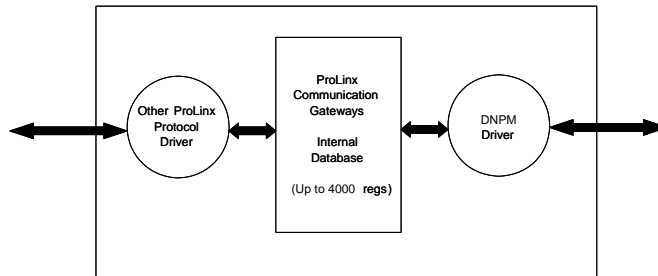

### 1.2 DNP Master Database Layout

Central to the functionality of the DNP driver is the database. This database is used as the interface between remote DNP devices and the other protocol implemented on a module. The content and structure of the user data area of the database is completely user defined. The following illustration shows the general format of the module's database:

DATA AREA		DATA SIZE
DNP DATA	BINARY INPUTS	1 WORD PER 16 POINTS
	ANALOG INPUTS	1 WORD PER POINT
	COUNTER DATA	2 WORDS PER POINT
	BINARY OUTPUTS	1 WORD PER 16 POINTS
	ANALOG OUTPUTS	1 WORD PER POINT

The first word of the module's database contains the first 16 points of binary input data (if defined). It is important to understand how the data is mapped to the database so that it can be accessed by the other protocol. Each DNP data type has a fixed size. This size is used in conjunction with the number of points configured for the type to determine the size and location in the database. The following is an example of a user database with a defined set of point counts:

DATA AREA		REGISTERS	CFG VALUES
DNP DATA	BINARY INPUTS	0 TO 1	2
	ANALOG INPUTS	2 TO 51	50
	COUNTER DATA	52 TO 71	10
	BINARY OUTPUTS	72 TO 73	2
	ANALOG OUTPUTS	74 TO 113	40
USER DATA	REMAINING DATA AREA	114 TO 3999	



Note that the order of the data types is fixed by the driver. In order to access the binary input data read from a slave device, registers 0 to 1 are used. To set analog output data to pass to the driver for remote slaves, registers 74 to 113 are used. Register 74 contains the value for analog output point 0, and register 113 contains the value for analog output point 39.

The other protocol on the ProLinx module should place data in the binary and analog output data areas. Values set will be passed by the master driver to slave units on the network.

The other protocol on the ProLinx module should retrieve the data for the binary and analog inputs and counters as these are obtained by the master driver from slave units. This monitored data area should not be altered by the other protocol on the module.

### 1.3 DNP Master Driver Data Flow

The DNP Master Driver allows the module to generate read and write commands issued to slave units on the DNP network. The following flow chart and associated table describe the flow of data into and out of the module.

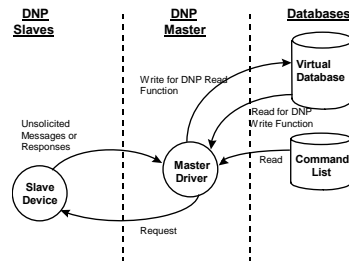

Step	Description
1	The DNP Master driver receives the configuration information from the Flash memory in the module. This information configures the serial port and define the Master node characteristics.
2	The Master Driver issues a read or write command to the DNP Slave's node address. The Slave device qualifies the message then issues a response containing the information requested by the master..
3	After the module accepts the response, the data is immediately transferred to or from the internal database in the module. If the command is a read command (binary input, analog input, counter, event, and so on), the data is written to the module database. If the command is a write command (binary output or analog output), the data is read directly from the database.
4	Error/Status data are available in a Status Block that can be placed anywhere in the module's database. This area can be accessed by the other protocol on the module using the correct database offset.



## 2 Port Physical and Protocol Specifications

### *In This Chapter*

- ❖ DNP 3.0 Master Port Specifications ..... 11
- ❖ Serial Port Specifications..... 11

### 2.1 DNP 3.0 Master Port Specifications

Type	Specifications
General Parameters	
Internal Database	Binary Inputs: 0 to 500 word count Analog Inputs: 0 to 500 points of analog input data Counters: 0 to 250 points of counter data Binary Outputs: 0 to 500 word count Analog Outputs: 0 to 500 points of analog output
Communication parameters	Port 0: Baud Rate: 110 to 115,200 baud Stop Bits: 1 Data Size: 8 bits Parity: None RTS Timing delays: 0 to 65535 milliseconds
DNP Mode	DNP 3.0 Master - Level 2
DNP Object Support	See Reference chapter for full Object Definition document
DNP Master	
Node address	0 to 65534 (software selectable)
Slave count	The module supports the definition of up to 40 slave devices
Command count	The module supports the definition of up to 300 user defined commands to interface with remote slave devices

### 2.2 Serial Port Specifications

Type	Specifications
Serial Ports	
Serial Port Cables (DB-9M Connector)	One DIN to DB-9M cable included per configurable serial port
Port 0	RS-232/422/485: jumper selectable DB-9M connector Hardware Handshaking: RTS,CTS,DTR,DSR,DCD

---

<b>Type</b>	<b>Specifications</b>
Serial Port Isolation	2500V RMS port-to-port isolation per UL 1577. 3000V DC min. port to ground and port to logic power isolation.
Serial Port Protection	RS-485/422 port interface lines TVS diode protected at +/- 27V standoff voltage. RS-232 port interface lines fault protected to +/- 36V power on, +/- 40V power off.
Collision Avoidance	The DNP collision avoidance scheme can be enabled for the port when more than one slave device is present on the network and unsolicited messaging is supported.

---

### 3 DNPM Protocol Configuration

*In This Chapter*

- ❖ [DNP Master]..... 13
- ❖ [DNP Master Database]..... 14
- ❖ [DNP Master Slave List] ..... 15
- ❖ [DNP Master Commands]..... 16

The following topics are excerpted from a configuration file showing typical examples of the DNPM Port of a CFG file for a DNPM port. Shipped with each unit (or available from the web) is a default configuration file that can easily form the basis for a working solution. This file can either be downloaded from the ProSoft web site at [www.prosoft-technology.com](http://www.prosoft-technology.com), or transferred from the module. Refer to the *ProLinx Reference Guide* for information on configuring and downloading .CFG files to ProLinx modules.

#### 3.1 [DNP Master]

The [DNP Master] section of the **CFG** file sets the DNP 3.0 port communication parameters and the protocol specific parameters. The following example and table lists the parameters defined in this section:

```
[DNP Master]
Internal ID          : 1          #0-65534 identification code for this unit
DNP Database Offset : 2000       #0-3999 Start of DNP data in internal DB

Baud Rate           : 19200      #Baud rate for port 110-115200
RTS On              : 0          #0-65535 milliseconds before message
RTS Off             : 0          #0-65535 milliseconds after message
Min Response Delay  : 10         #0-65535 milliseconds before response sent

# Collision Avoidance parameters
Collision Avoidance : N          #Use Collision Avoidance (Yes or No)
CD Idle Time        : 10         #0-32000 mSec min idle time before transmit
CD Time Before Receive : 12      #0-65535 milliseconds before receive
```

Variable Name	Data Range	Description
[DNP Master]		This section header defines the start of the DNP Master parameter set.
Internal Master ID:	0 to 65534	This is the DNP address for the module. All messages assigned to this address from the master are processed by the module.
DNP Database Offset	0 to 3999	Offset in which to place DNP data. Specifies the start of DNP data in the internal database.
Baud Rate:	Baud Rate from Table	Port Baud Rate: 300, 600, 1200, 2400, 4800, 9600, 19200, 384 (38400), 576 (57600), 115 (115200)

Variable Name	Data Range	Description
RTS On:	0 to 65535	This value represents the number of 1 ms increments to be inserted between asserting the RTS modem line and the actual transmission of the data.
RTS Off:	0 to 65535	This value represents the number of 1 ms increments to be inserted after the last character of data is transmitted before the RTS modem line is dropped.
Min Response Delay:	0 to 65535	Minimum time between receiving a request and transmitting a response. Allows master time to disable transmitter on an RS-485 network.
Collision Avoidance Parameters		
Collision Avoidance:	Yes or No	This parameter defines if the collision avoidance functionality is to be applied to the port. If the parameter is set to No, collision avoidance is not used. It will be used if set to Yes. If collision avoidance is used, it requires a special cable.
CD Idle Time:	0 to 32000	Defines the minimum number of milliseconds to wait before transmitting a message after the CD signal is recognized as low.
CD Time Before Receive:	0 to 65535	Defines the number of milliseconds to wait before receiving characters after the CD signal is recognized as high.

### 3.2 [DNP Master Database]

The [DNP Master Database] section of the **CFG** file sets the size of each data type utilized by the module in order to define the database. The example and following table lists the parameters defined in this section:

```
[DNP Master Database]
Binary Inputs      : 2      #0-500 word count to hold BI data
Analog Inputs     : 50     #0-500 points of analog input data
Counters          : 10     #0-250 points of counter data
Binary Outputs    : 2      #0-500 word count to hold BO data
Analog Outputs    : 40     #0-500 points of analog output data
```

Variable Name	Data Range	Description
[DNP Master Database]		This section defines the database for the module
Binary Inputs:	0 to 500	Number of words for digital input points to configure in the DNP Master device. Each word contains 16 binary input points.
Analog Inputs:	0 to 500	Number of analog input points to configure in the DNP Master device. Each point will occupy a one-word area in the module memory.
Counters:	0 to 250	Number of counter points to configure in the DNP Master device. Each point will occupy a two-word area in the module memory. This number corresponds to the number of frozen counters. The application maps the counters to the frozen counters directly.
Binary Outputs:	0 to 500	Number of words for digital output points to configure in the DNP Master device. Each word contains 16 binary output points.
Analog Outputs:	0 to 500	Number of analog output points to configure in the DNP Master device. Each point will occupy a one word area in the module memory.

### 3.3 [DNP Master Slave List]

The DNP Master Slave List defines information about each slave that will be used by the master port. Up to 40 devices can be defined for the master driver. Each node must have an entry. The following example and tables define the data required for each node:

```
[DNP Master Slave List]
# This section is used to store information about each slave to be
# used by the master port. There must be an entry in this table for each
# node to be used in the command list. Two of the parameters in this list
# are coded values:
#   Conf Mode ==> 0=Never, 1=Sometimes and 2=Always (select 0).
#   Flags is bit coded as follows:
#     Bit 0 (decimal 1) ==> Enable the slave
#     Bit 1 (decimal 2) ==> Use Unsolicited messaging with this slave
#     Bit 2 (decimal 4) ==> Use delay measurement with this slave
#     Bit 3 (decimal 8) ==> Auto time synchronization enabled
#
START
#   Node DL Conf      Conf      Conf  App Rsp
# Address  Mode  Timeout  Retry  Timeout  Flags
#         2    0    1000    0    2000    9
END
```

Two parameters in the list contain coded values as shown in the example.

Variable Name	Value	Description
Node Address		Node address for slave being defined
Conf Mode	0, 1, or 2	0=Never, 1=Sometimes, 2=Always (Select 0)
Conf Timeout		Data Link Layer Confirmation timeout
Conf Retry		Data Link Layer Confirmation retry count
App Resp Timeout		Application layer timeout
Flags		Bit 0 (decimal 1) = Enable the slave Bit 1 (decimal 2) = Use unsolicited messaging with this slave Bit 2 (decimal 4) = Use delay measurement with this slave Bit 3 (decimal 8) = Auto time synchronization enabled

The following table describes the information required for each column of each record in the slave list section. A record is required for each slave device to be interfaced with by the module.

Column	Variable Name	Data Range	Description
1	DNP Slave Address	0 to 65534	This is the slave address for the unit to override the default values.
2	Data Link Confirm Mode	Coded Value (0=Never, 1=Sometimes, 2=Always).	This value specifies if data link frames sent to the remote device require a data link confirm. This parameter should be set to zero for almost all applications.
3	Data Link Confirm Timeout	1 to 65535 milliseconds	This parameter specifies the time to wait for a data link confirm from the remote device before a retry is attempted.

Column	Variable Name	Data Range	Description
4	Maximum Retries for Data Link Confirm	0 to 255 retries	Maximum number of retries at the Data Link level to obtain a confirmation. If this value is set to 0, retries are disabled at the data link level of the protocol. This parameter is only used if the frame is sent with confirmation requested.
5	Application Layer Response Timeout	1 to 65535 milliseconds	Time-out period the master will wait for each response message fragment. If data link confirms are enabled, make sure the timeout period is set long enough to permit all data confirm retries.
6	Slave Mode	Coded Value (Bit 0 = Enable, Bit 1 = Unsol Msg, Bit 2 = Use DM, Bit 3 = Auto Time Sync).	This word contains bits that define the slave mode. The slave mode defines the functionality of the slave device and can be combined in any combination. The fields have the following definition: Enable: determines if this slave will be used. Unsol Msg: causes an enabled unsolicited response message to be sent to the slave when its RESTART IIN bit is set. This parameter is also required for unsolicited message reporting by the IED unit. Use DM: uses delay measurement. Auto Time Sync: time synchronization used when NEED TIME IIN bit set.

### 3.4 [DNP Master Commands]

The DNP Master Commands section contains the list of commands to process on the master port. Up to 300 commands can be defined in this section to monitor and control all the slave devices on the network. Node addresses in the command list must contain an entry in the [DNP Slave List]. The following example and table define the data required for each command:

```
[DNP Master Commands]
# This section contains the list of commands to process on the master port.
# Node addresses present in the command list must have an entry in the
# [DNP Slave List]. Commands with nodes not present in the list will not be
# executed.
#
START
#   1       2       3       4   5       6       7       8       9
#Flags/   Node   Data   Data  Cmd  Device Point  IED DB   Poll
#Enable Address Object Variation Func Address Count Address Interval
      6       2       1       0   1       0    -32     0       0
      6       2      -12      257  3       0   2000     0       10
      6       2       20       0   1       0     5       0       0
      6       2       30       0   1       0    -50     0       0
      6       2       41       2   5       0     4       0       0
END
```



Variable Name	Value	Description
Flags Enable		See discussion that follows
Node Address		Specifies the node address of the slave unit for which the command is to be sent
Data Object		This is the DNP data object code for the command (For issuing a CROB command refer to the following discussion).
Data Variation		This is the DNP data variation for the command
Cmd Func		This is the DNP command code to be used when forming the command request
Device Address		This is the starting address in the device (point address) for the command
Point Count		This field defines the number of points to request from the slave device. If the parameter is set to a negative number (-n), the module will only process the first -n number of points. For example, if this field is set to -3, only the first 3 points will be accepted into the database.
IED DB Address		This field defines the internal address in the master driver's database to be associated with the command. If the command is a read command, the data read will be placed at this address. If the command is a write command, the data to be written will be sourced from this address.
Poll Interval		This field specifies the minimum number of seconds to wait between the issuance of the command.

The value for the Flags/Enable and point count are dependent on the type of function (input or output) being executed by the module. The two diagrams display this relationship:

**Inputs:**

Port/Flags Bits	Description	Decimal Equivalent
0	Not Used	
1	Communication Port (1=DNP Master Port)	2
2	Enable/Disable Command (1=Enable, 0=Disable)	4
3 to 7	Not Used	

If # of Points < 0, then use Qual 06h (all points, packaged & -Points = # of points to consider)

If Address in Slave = 0 & # of Points > 0, then use Qual 00h or 01h (points 0 to # of points -1)

If Address in Slave > 0 & # of Points > 0, then use Qual 00h or 01h (address to address+# of points-1)

**Outputs:**

Port/Flags Bits	Description	Decimal Equivalent
0	Not Used	
1	Communication Port (1=DNP Master Port)	2
2	Enable/Disable Command (1=Enable, 0=Disable)	4
3	Poll Type (0=Poll, 1=Exception)	8
4 to 7	Not Used	

Port/Flags Bits	Description	Decimal Equivalent
-----------------	-------------	--------------------

If Address in Slave = 0 & # of Points > 0, then use Qual 17h or 28h (# of points specified starting at point 0)

If Address in Slave > 0 & # of Points > 0, then use Qual 17h or 28h (points from address to address+# of points-1)

If # of Points <= 0, then ignore because this is illegal for outputs.

Other rules that must be observed when constructing commands are as follows:

**Address in Slave:** This value must be >= 0. If it is set to a value < 0, the command will be ignored.

**Point Count:** This value must be set to a value other than 0. If the value is set to 0, the command will be ignored.

**Poll Interval:** 0=Continuous, >0=Number of seconds between polls. If exception processing is used for output commands, this parameter is ignored, and the command will only be issued when data changes.

The following two examples of commands display the interrelationship of the parameters used to construct a command:

**BINARY INPUT COMMAND EXAMPLES:**

	Port/Flg	Slave	Object	Var	Func	Addr	Pnt Cnt	IED DB	Poll Int
WORD	0	1	2	3	4	5	6	7	8
VALUE	6	2	1	0	1	0	32	0	0

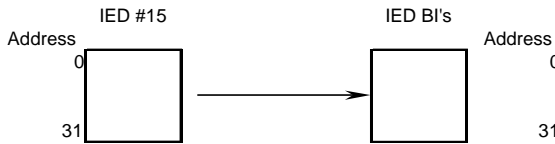

Command for DNP Master Port, Enabled.  
 IED Unit 2 is to be polled.  
 Object type is 1 (Binary Input).  
 Variation of 0 (default variation).  
 Function 1 is for a read.  
 Point address 0 is starting address in IED device  
 Point count of 32 indicates points 0-31 to be polled.  
 IED DB address of 0 is where first data point is placed. (within BI database)  
 Poll command as soon as possible.

**BINARY OUTPUT COMMAND EXAMPLES:**

	Port/Flg	Slave	Object	Var	Func	Addr	Pnt Cnt	IED DB	Poll Int
WORD	0	1	2	3	4	5	6	7	8
VALUE	14	2	12	1	5	0	16	25	0

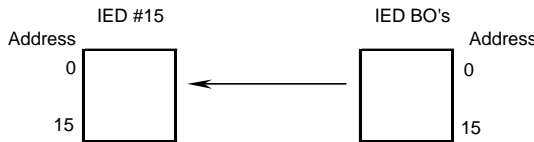

Command for Port 2, Enabled, only operate on point change.  
 IED Unit 2 is to be controlled.  
 Object type is 12 (Binary Output Control).  
 Variation of 1 (Control Relay Output Block).  
 Function 5 is for direct operate.  
 Slave address of 0 is starting point in IED.  
 16 points are transferred.  
 IED DB address of 0 is first source point.  
 Command not a polled command.  
 Write only on change of data in BO database.

Note: CROB commands (object 12) exceeding a count of 16 are not recommended. Many IEDs only support one transport layer and a count > 16 may cause the IED device to not accept the new data value being written by the ProLinx module.

The following table aids in defining the command list as it displays the values required for certain DNP data types:

	<b>Digital input</b>	<b>Digital input Events</b>	<b>Digital Output</b>	<b>Counter</b>
0	Port/Flags	Port/Flags	Port/Flags	Port/Flags
1	Slave Address	Slave Address	Slave Address	Slave Address
2	1	2	12	20
3	0, 1 or 2	0, 1, 2 or 3	1*	0, 5 or 6
4	1*	1*	3, [4], 5 or 6	1, 7, 8, 9 or 10
5	Address in Slave	Address in Slave	Address in Slave	Address in Slave
6	# of Points	# of Points	# of Points	# of Points
7	IED DB Address		IED DB Address	IED DB Address
8	Poll Interval	Poll Interval	Poll Interval	Poll Interval

	<b>Frozen Counter</b>	<b>Analog Input</b>	<b>Analog Input Events</b>	<b>Analog Output</b>
0	Port/Flags	Port/Flags	Port/Flags	Port/Flags
1	Slave Address	Slave Address	Slave Address	Slave Address
2	21	30	32	41
3	0, 9 or 10	0, 1, 2, 3 or 4	0, 1, 2, 3 or 4	2*
4	1*	1*	1*	3, [4], 5 or 6
5	Address in Slave	Address in Slave	Address in Slave	Address in Slave
6	# of Points	# of Points	# of Points	# of Points
7	IED DB Address	IED DB Address		IED DB Address
8	Poll Interval	Poll Interval	Poll Interval	Poll Interval

	<b>Time and Date</b>	<b>Class 0</b>	<b>Class 1</b>	<b>Class 2</b>
0	Port/Flags	Port/Flags	Port/Flags	Port/Flags
1	Slave Address	Slave Address	Slave Address	Slave Address
2	50	60	60	60
3	1*	1	2	3
4	2*			
5				
6	1	1	1	1
7				
8	Poll Interval	Poll Interval	Poll Interval	Poll Interval

	<b>Class 3</b>	<b>Cls 1, 2 &amp; 3</b>	<b>Cls 0, 1, 2 &amp; 3</b>	<b>[Clear Restart Bit]</b>
0	Port/Flags	Port/Flags	Port/Flags	Port/Flags
1	Slave Address	Slave Address	Slave Address	Slave Address
2	60	60	60	80
3	4	5	6	1
4				2
5				7
6	1	1	1	1
7				
8	Poll Interval	Poll Interval	Poll Interval	

	<b>Cold Restart</b>	<b>Warm Restart</b>	<b>Enable Unsol. Msg</b>	<b>Disable Unsol. Msg</b>
0	Port/Flags	Port/Flags	Port/Flags	Port/Flags
1	Slave Address	Slave Address	Slave Address	Slave Address
2	0	0	0	0
3				
4	13	14	20	21
5				
6	1	1	1	1
7				
8				

	<b>Word Offset</b>	<b>Definitions</b>
* Value Assumed	0	Port/Flags
[ ] Automatically implemented	1	Slave Address
	2	Object
	3	Variation
	4	Function
	5	Address in Slave
	6	Point Count
	7	IED DB Address
	8	Poll Interval

A special data type is added to the module in order to generate CROB commands to control binary outputs. The following table shows the format to be utilized when this command is desired:

Column	Definitions	Description
1	Port/Flags	Set this parameter to 6 to enable the command in the list.
2	Slave Address	This is the IED node address for the slave to consider on the network.
3	Object	Object type always -12
4	CROB Image (L) Pulse Count (H)	The CROB Image parameter contains the CROB image for the command. Refer to the following table for the definition of this block.  The pulse count parameter specifies the number of pulses to generate for pulse output control. This parameter has a range of 0 to 255 as the value is a byte parameter in the CROB. If a value of zero is entered, the operation will not execute.
5	Function	Function codes 3, 5 and 6 supported. Function code 4 is automatically sent after a successful function 3.
6	Address in Slave	Point in IED to consider with the CROB.
7	Pulse Time	This parameter sets the on and off time to use if the pulse operation is to associate with this command.
8	DB Address	This is address in the module's internal database to use as a trigger for the command. If a value other than 0 is found in the register, the command will be executed. The database register will be set to 0 after the command is placed in the command queue.
9	Poll Interval	This field specifies the minimum number of seconds to wait between the issuance of the command.

The value for the CROB image is that specified in the DNP specification. The following table lists the bits that comprise this value:

Bits	Definitions	Description
0 to 3	Code	These bits determine the control operation to be performed by the command: 0=No operation, 1=Pulse on, 2=Pulse off, 3=Latch on and 4=Latch off. All other values are undefined in the DNP protocol.
4	Queue	0=Normal (execute once), 1=Requeue (place at end of queue after operation).
5	Clear	This parameter clears the queue. If the value is set to zero, the queue is not affected. If the value is set to 1, the queue will be cleared.
6 to 7	Trip/Close	These two bits select the trip or close relay. For close relay control, set the bits to 01. For trip relay control, set the bits to 10. A value of 00 for the bits is used for single point control of normal digital output points.

### Example 1 – Digital Output

No CROB Control - Does not allow full control of Control Operation, Queue, Clear, Trip/Close, and Pulse count. Only Latch On/Off supported and count is set 1, on and off time set to zero, 1 and status set to zero.

- 1
- 2
- 3 12
- 4
- 5
- 6
- 7
- 8
- 9 Low byte of parameter value is used as Poll Interval

### Example 2 – Digital Output

For Select (and implied operate).

With CROB control - Allows full control of Control Operation, Queue, Clear, Trip/Close and Pulse count.

- 1
- 2
- 3 -12
- 4 Lo byte of parameter value is object variation
- 5 3, [4]
- 6
- 7
- 8
- 9 Low byte of parameter value is used as Poll Interval

### Example 3 – Digital Output

For Direct Operate (with/without rack).

With CROB control - Allows full control of Control Operation, Queue, Clear, Trip/Close, and Pulse/count.

- 1
- 2
- 3 -12
- 4 Low byte is object variation. High byte = Pulse count = 1
- 5 Low byte = Function (5 or 6)
- 6
- 7
- 8
- 9 Not used.

Besides issuing commands to slave devices, the command list is also used to map data received in event messages to the proper database locations. For example, Slave 1 and Slave 1 both possess binary point 0. When an event from each slave is received, the data entered into the command list is utilized to place the data for the two events in the correct database location. When the command list is read by the module it forms lists for each slave relating the address in the device to that in internal database of the module. The following illustration shows how the module stores this data:

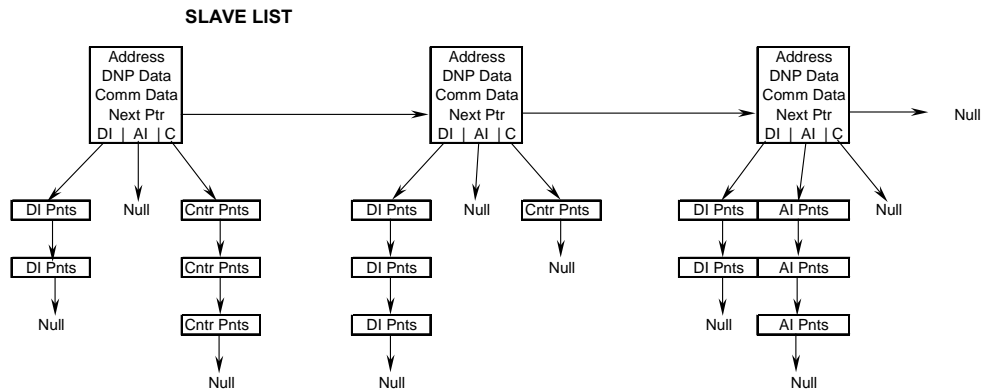

DI Pnts are generated for each command with an object type of 1.  
AI Pnts are generated for each command with an object type of 30.  
Cntr Pnts are generated for each command with an object type of 20 or 21.

The point lists are used by the module to determine the destination of all data read by the module from the IED's. When the master receives a poll response or an unsolicited response message, the points in the message are mapped to the IED database using the point lists. For example, when the master receives a value for binary input point 10 from slave unit 14, the following steps are performed by the module:

- 1 First the module searches the slave list to make sure slave 14 is valid for the module. If the slave not found the message is ignored. If the slave is found, the module saves the pointer to the binary input point list.
- 2 Point number 10 is searched for in the binary input point list. If the point is found in the DNP point list, the new value is stored at the correct offset in the BI database. If the point is found in the IED point list, the new value is stored at the correct offset in the IED database. If the point is not found in either point list, it is ignored.

Each node in the point lists contain the start-stop IED point ranges and the IED database offset values. These values are read by the module from the command list each time the module performs the restart operation. If the database address value is set to -1, the database is not used for the specified point range.

When the lists are formed by the module, the enable/flag field is ignored. Therefore, you can place commands that will not be executed in the command list and are only used for data mapping.





## 4 Communication Port Cables

### *In This Chapter*

- ❖ DNP 3.0 Master Port ..... 25
- ❖ Port 0, 1, 2, 3: RS-232 - Null Modem (DTE with Hardware Handshaking) 26
- ❖ Port 0, 1, 2, 3: RS-232 - Null Modem (DTE without Hardware Handshaking) ..... 27
- ❖ Port 0, 1, 2, 3: RS-232 - DTE to DCE Modem Connection ..... 27
- ❖ Collision Avoidance (DNP modules only) ..... 28
- ❖ Port 0, 1, 2, 3: RS-422 Interface Connections ..... 29
- ❖ Port 0, 1, 2, 3: RS-485 Interface Connections ..... 29

This section contains information on the cable and pin assignments for the ProLinux module's serial ports (RS-232/422/485). The ProLinux module will come with one to five serial ports, depending on the configuration purchased. In all cases, the protocol serial ports will have the same pinouts.

Example: The 5202-MNET-MCM4 module contains five serial communication ports; four configurable protocol application ports and one Configuration/ Debug port. The 5201-MNET-MCM module contains two serial communication ports; one configurable protocol application port and one Configuration/Debug port.

Each physical serial port has an eight-pin Mini-DIN jack connector. A six-inch Mini-DIN-8Male to DB-9Male adapter cable is provided for each serial port. The DB-9M provides connections for RS-232, wired as Data Terminal Equipment (DTE), RS-422 and RS-485. The diagrams in the following topics detail the pin assignments for several possible electrical interface connections.

### 4.1 DNP 3.0 Master Port

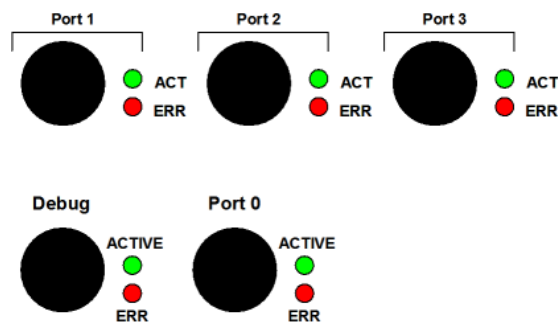

The ProLinx module supports the DNP 3.0 protocol as a Master on one port. This port is fully configurable.

The relationship between the port labeling on the front of the ProLinx module and the application is as follows:

Port Label	Function
Debug	Debug/Configuration
Port 0	DNP Master Port
Following ports only exist on multiple port units	
Port 1	Not available to DNP Driver
Port 2	Not available to DNP Driver
Port 3	Not available to DNP Driver

The DNP Master port can be used to continuously interface with a DNP slave devices over a serial communication interface (RS-232, RS-422 or RS-485).

#### 4.2 Port 0, 1, 2, 3: RS-232 - Null Modem (DTE with Hardware Handshaking)

This type of connection is used when the device connected to the module requires hardware handshaking (control and monitoring of modem signal lines; Use CTS parameter set to **YES**).

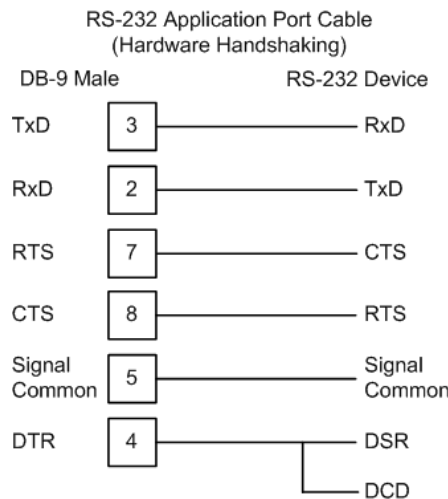

### 4.3 Port 0, 1, 2, 3: RS-232 - Null Modem (DTE without Hardware Handshaking)

This type of connection can be used to connect the module to a computer or field device communication port.

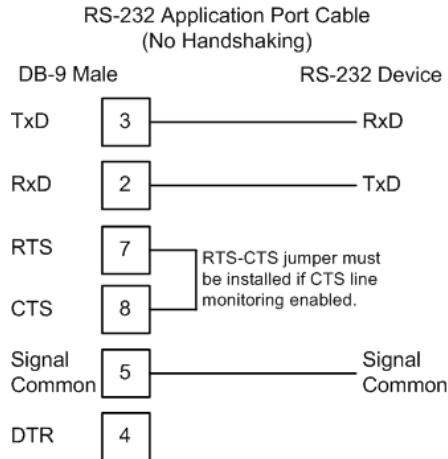

Note: If the port is configured with the *Use CTS* set to YES, then a jumper is required between the RTS and the CTS line on the module connection.

### 4.4 Port 0, 1, 2, 3: RS-232 - DTE to DCE Modem Connection

This type of connection is required between the module and a modem or other communication device.

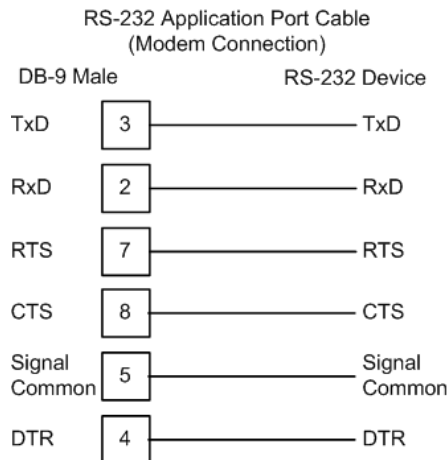

The *Use CTS Line* parameter for the port configuration should be set to **YES** for most modem applications.

### 4.5 Collision Avoidance (DNP modules only)

The RTS line is controlled by the RTS on and off parameters set for the port. If the CTS line is used (usually only required for half-duplex modems and not defined for use in the DNPS specification), the RTS and CTS lines must either be connected together or connected to the modem. The following illustration shows the cable required when connecting the port to a modem.

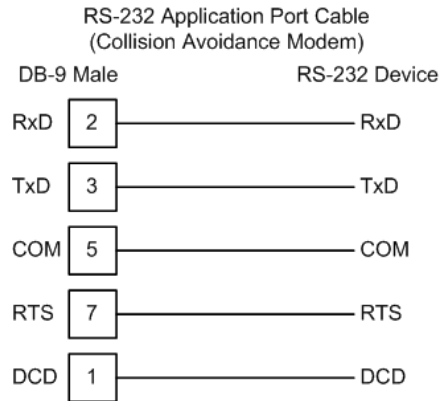

If collision avoidance is used in a point-to-point connection on the RS-232 interface, the following cable should be used.

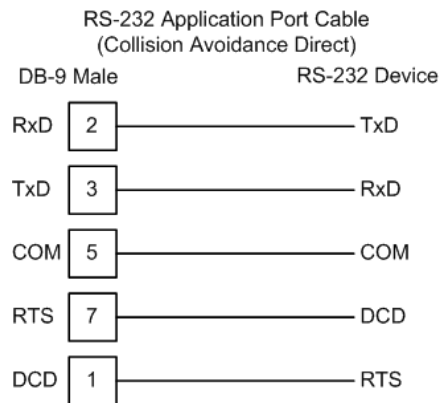

## 4.6 Port 0, 1, 2, 3: RS-422 Interface Connections

The following illustration applies when the RS-422 interface is selected.

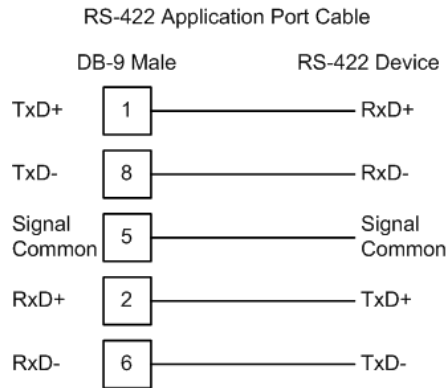

## 4.7 Port 0, 1, 2, 3: RS-485 Interface Connections

The following illustration applies when the RS-485 interface is selected.

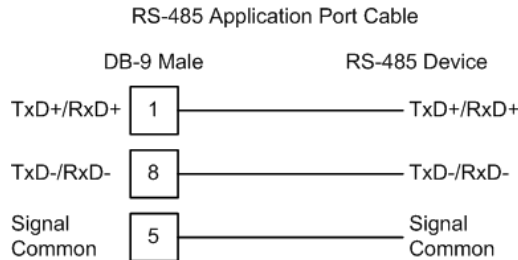

**NOTE:** This type of connection is commonly called a *RS-485 half-duplex, 2-wire* connection. If you have RS-485 4-wire, full-duplex devices, they can be connected to the module's serial ports by wiring together the TxD+ and RxD+ from the two pins of the full-duplex device to Pin 1 on the module and wiring together the TxD- and RxD- from the two pins of the full-duplex device to Pin 8 on the module. As an alternative, you could try setting the module to use the RS-422 interface and connect the full-duplex device according to the RS-422 wiring diagram (page 29). For additional assistance, please contact ProSoft Technical Support.



## 5 LED Indicators

### *In This Chapter*

- ❖ Common module LEDs ..... 31
- ❖ LEDs for Port 0 Serial Port ..... 31
- ❖ 4101 Series LEDs ..... 32

Troubleshooting the operation of the DNP Master port can be performed using several methods.

The first and quickest is to scan the LEDs on the module to determine the existence and possibly the cause of a problem. This section provides insight into the operation of the Serial Port status LEDs. Information on the module's other LEDs can be found in the *ProLinx Reference Guide*.

### 5.1 Common module LEDs

LED	State	Description
Power	Off	Power is not connected to the power terminals or source is insufficient to properly power the module (800mA at 24vdc minimum required)
	Green Solid	Power is connected to the power terminals. Verify that the other LEDs for operational and functional status come on briefly after power-up (check for burned-out LEDs).
Fault	Off	Normal operation.
	Red Solid	A critical error has occurred. Program executable has failed or has been user-terminated and is no longer running. Press Reset p/b or cycle power to clear error. If not, use the Debug procedures described later in this manual.
Cfg	Off	Normal operation.
	Amber Solid	The unit is in configuration mode. The configuration file is currently being downloaded or, after power-up, is being read, the unit is implementing the configuration values, and initializing the hardware. This will occur during power cycle, or after pressing the reset button. It also occurs after a cold/warm boot command is received.
Err	Off	Normal operation.
	Flashing	An error condition has been detected and is occurring on one of the application ports. Check configuration and troubleshoot for communication errors.
	Solid Red	This error flag is cleared at the start of each command attempt (master/client) or on each receipt of data (slave/adaptor/server); so, if this condition exists, it indicates a large number of errors are occurring in the application (due to bad configuration) or on one or more ports (network communication failures).

## 5.2 LEDs for Port 0 Serial Port

Some ProLinx modules have three extra serial ports. Each of these serial ports has two LEDs indicating status.

LED	Color	Description
Port 0 - ACT	Off	No activity on the port.
	Green Flash	The port is either actively transmitting or receiving data
Port 0 - ERR	Off	Normal state. When off and Port Active led is indicating activity, there are no communication errors
	Red On or Flashing	Activity on this led indicates some communication error was detected, either during transmit or receive

## 5.3 4101 Series LEDs

LED	State	Description
Power	Off	Power is not connected to the power terminals.
	Green Solid	Power is connected to the power terminals. Verify that the other LEDs for operational and functional status light.
Fault	Off	Normal operation.
	Red Solid	The Debug/Configuration mode is active (applies to modules that support pass-through on Debug port - such as DFCM units). If CFG LED is not on, a critical error has occurred. Program executable has failed or has been user-terminated and is no longer running. Press Reset p/b or cycle power to clear error. If not, use the Debug procedures described later in this manual.
CFG	Off	Normal operation.
	Amber Solid	If Fault LED is on, the Debug/Configuration Mode is active (if the module supports pass-through on the Debug port - such as DFCM units). If the Fault LED is off, the unit is in the configuration mode. The configuration file is being read and the unit is implementing the configuration values and initializing the hardware. This will occur during power cycle, or after pressing reset button. It also occurs after a cold/warm boot command is received.
ERR	Off	Normal operation.
	Flashing	An error condition has been detected and is occurring. Check configuration.
	Solid Red	This condition is indicative of a large number of errors in the application interface communications. The module's error flag is cleared at the start of each command (master/client) or receipt of data (slave/adaptor/server).



## 6 Reference

### *In This Chapter*

- ❖ Error Codes ..... 33
- ❖ Device Profile ..... 37
- ❖ Subset Definition ..... 39
- ❖ Command List Entry Form..... 45

### 6.1 Error Codes

#### 6.1.1 Module Error Codes

These error codes are generated by the module in response to communication problems on an emulated slave port or configuration errors. Review the error list to view the last set of 60 errors generated by the module. The error codes are listed in the following tables:

#### Slave Port Communication Errors

<b>Error Code</b>	<b>Name</b>	<b>Description</b>
0	OK	The module is operating correctly and there are no errors.
10	DNP synchronization error (Physical Layer Error)	Extra bytes are received before the start bytes (0x05 and 0x64).
11	DNP overrun error (Physical Layer Error)	Mainline Data Link Layer routine could not read data received on DNP port before it was overwritten.
12	DNP length error (Physical Layer Error)	Length of message does not match length value in message.
13	DNP bad CRC error (Data Link Layer Error)	Computed CRC value for message does not match that received in message.
14	DNP user data overflow error (Transport Layer Error)	Application layer received a message fragment buffer which is too small.
15	DNP sequence error (Transport Layer Error)	Sequence numbers of multi-frame request fragments do not increment correctly.
16	DNP address error (Transport Layer Error)	Source addresses contained in multi-frame request fragments do not match.
17	DNP bad function code error (Application Layer Error)	Function code received from DNP master is not supported for selected object/variation.
18	DNP object unknown error (Application Layer Error)	Slave does not have the specified objects or there are no objects assigned to the requested class.
19	DNP out of range error (Application Layer Error)	Qualifier, range or data fields are not valid or out of range for the selected object/variation.

<b>Error Code</b>	<b>Name</b>	<b>Description</b>
20	DNP message overflow error (Application Layer Error)	Application response buffer overflow condition. The response message from the slave is too long to transmit.
21	DNP master multi-frame message error (Application Layer Error)	Received a multi-frame message from the DNP master. This application does not support multi-frame messages from the master.

***System Configuration Errors***

<b>Error Code</b>	<b>Name</b>	<b>Description</b>
100	Too many binary input points	Too many binary input points are configured for the module. Maximum value is 15360.
101	Too many binary output points	Too many binary output points are configured for the module. Maximum value is 15360.
102	Too many counter points	Too many counter points are configured for the module. Maximum value is 480.
103	Too many analog input points	Too many analog input points are configured for the module. Maximum value is 960.
104	Too many analog output points	Too many analog output points are configured for the module. Maximum value is 960.
105	Too many binary input events	Too many binary input events are configured for the module. Maximum value is 400.
106	Too many analog input events	Too many analog input events are configured for the module. Maximum value is 400.
107	Invalid analog input deadband	Deadband value for analog input events is out of range. Value must be in the range of 0 to 32767.
108	Not enough memory	There is not enough memory in the module to configure the module as specified.
109	Invalid block transfer delay for blocks 251 and 252 (error/status blocks)	Block transfer delay value specified is too low.
110	File count invalid	The file count must be in the range of 0 to 6.
111	Invalid file record size	The file record size must be in the range of 1 to 120.
112	Invalid block identification code for file	The file block transfer code must be in the range of 100 to 120.

***DNP Port Configuration Errors***

<b>Error Code</b>	<b>Name</b>	<b>Description</b>
212	Invalid DNP address	The DNP address specified in the configuration is not valid (0 to 65534).
213	Invalid DNP port baud rate	The baud rate code specified in the configuration is not valid.
219	Invalid DNP data link layer confirm mode	The data link confirmation mode code is not valid in the configuration.
220	Invalid DNP data link confirm time-out	The data link time-out period specified in the configuration is 0. It must be an integer in the range of 1 to 65535.
222	Invalid DNP select/operate arm time duration	The select/operate arm timer is set to 0. It must be an integer in the range of 1 to 65535.
223	Invalid DNP application layer confirm time-out	The application layer confirm time-out value is set to 0. It must be an integer in the range of 1 to 65535.
224	Invalid DNP write time interval	The write time interval is not in the data range in the configuration. The value must be in the range of 0 to 1440.

Error Code	Name	Description
225	Invalid DNP unsolicited response mode	The unsolicited response mode code is not valid in the configuration.
226	Invalid DNP unsolicited response minimum quantity for Class 1	The unsolicited response minimum quantity for Class 1 is not valid in the configuration. Value must be an integer in the range of 1 to 255.
227	Invalid DNP unsolicited response minimum quantity for Class 2	The unsolicited response minimum quantity for Class 2 is not valid in the configuration. Value must be an integer in the range of 1 to 255.
228	Invalid DNP unsolicited response minimum quantity for Class 3	The unsolicited response minimum quantity for Class 3 is not valid in the configuration. Value must be an integer in the range of 1 to 255.
230	Invalid DNP unsolicited response destination address	The unsolicited response destination address is not valid in the configuration. Value must be in the range of 1 to 65534.

### 6.1.2 Command Error Codes

Command error codes are generated by the module's program. These errors are generated when an error occurs when issuing a request or processing a response of a command list function. The following tables list the command error codes used in the module:

#### General Command Errors

Error Code	Name	Description
1	Device not defined	The IED slave address referenced in the command is not defined in the module. Check to make sure there is an entry in the slave table for each slave device referenced in the command list.
2	Invalid command	This command is not valid. Check to make sure the slave address parameter is greater than or equal to zero and that the point count is not set to zero.
3	Object not supported	The data object in the command is not supported by the module. Refer to the DNP subset for the Master Port.
4	Command function not supported	The function specified in the command is not supported for the object type selected. Refer to the DNP subset for the Master Port.
10	Invalid binary input poll command	This binary input object command is not valid.
11	Invalid binary input event poll command	This binary input event object poll command is not valid.
20	Invalid binary output command function	This binary output command function is not valid.
30	Invalid counter poll command function	The counter object poll command contains an invalid function code.
31	Invalid counter poll command	This counter object poll command is not valid.
40	Invalid frozen counter poll command	This frozen counter object poll command is not valid.
50	Invalid analog input poll command	This analog input poll command is not valid.
51	Invalid analog input event poll command	This analog input event poll command is not valid.

<b>Error Code</b>	<b>Name</b>	<b>Description</b>
60	Invalid analog output poll command function	This analog output poll command contains an invalid function code.
61	Invalid analog output poll command	This analog output poll command is not valid.
70	Invalid time/date poll command	This time/date object poll command is not valid.
80	Invalid event poll command	This event poll command is not valid.

*Application Layer Errors*

<b>Error Code</b>	<b>Name</b>	<b>Description</b>
1000	Device index invalid	The device index in the request or response message is not found in the slave list.
1001	Duplicate request in application layer queue	The newly submitted message to the application layer already exists in the queue. The message is ignored.
1002	COM port device removed from system	The communication port for the message has been uninstalled on the system. This error should never occur as the communication ports are only uninstalled when the module's program is terminated.
1003	Sequence number error	The application sequence number in the response message does not match that based on the last request message. This indicates application layer messages are received out of order.
1004	Response to select before operate does not match	The select response message received from the slave module is not that expected from the last select request. This indicates a synchronization problem between the master and slave devices.
1005	Response does not contain date/time object	The response message from the slave device does not contain a date/time object. The master expects this object for the response message.
1006	Time-out condition on response	The slave device did not respond to the last request message from the master within the time-out set for the IED device. The application layer time-out value is specified for each IED unit in the slave configuration table in the module. This table is established each time the module performs the restart operation.
1007	Function code in application layer message not supported	The function code returned in the response message is not valid for the application layer or not supported by the module.
1008	Read operation not supported for object/variation	The application layer response message contains an object that does not support the read function.
1009	Operate function not supported for the object/variation	The application layer response message contains an object that does not support the operate function.
1010	Write operation not supported for the object/variation	The application layer response message contains an object that does not support the write function.

Use the error codes returned for each command in the list to determine the success or failure of the command. If the command fails, use the error code to determine the cause of failure.

## 6.2 Device Profile

<b>DNP V3.00 DEVICE PROFILE DOCUMENT</b>	
Vendor Name: ProSoft Technology, Inc.	
Device Name: DNP MASTER (VERSION 2.20)	
Highest DNP Level Supported : For Request: L2 For Responses: L2	Device Function: Master
<p>Notable objects, functions, and/or qualifiers supported in addition to the highest DNP level stated above (see attached table for complete list):</p> <p>The following features are configurable on the module: Collision avoidance</p>	
Maximum Data Link Frame Size (octets): Transmitted : 292 Received : 292	Maximum Application Fragment Size (octets): Transmitted : 2048 Received : 2048
Maximum Data Link Re-tries: Configurable from 0 - 255	Maximum Application Layer Re-tries: None
Requires Data Link Layer Confirmation: Configurable at module start-up (never, sometimes, & always)	
Requires Application Layer Confirmation:	

Time-outs while waiting for: Data Link Confirm : Configurable at module start-up (1 to 65535 mSec) Complete Application Fragment : Configurable at module start-up Application Confirm : Configurable at module start-up (1 to 65535 mSec) Complete Application Response : None	
Sends/Executes Control Operations: WRITE Binary Outputs : Never SELECT/OPERATE : Always DIRECT OPERATE : Always DIRECT OPERATE-NO ACK : Always  Count > 1 : Always (1 to 65535) Pulse On : Always Pulse Off : Always Latch On : Always Latch Off : Always  Queue : Never Clear Queue : Never	
Reports Binary Input Change Events when no specific variation requested:	Reports time-tagged Binary Input Change Events when no specific variation requested:
Sends Unsolicited Responses:	Sends Static Data in Unsolicited Responses:
Default Counter Object/Variation: Object : Variation :	Counters Roll Over at: 32 Bits
Sends Multi-Fragment Responses:	

### 6.3 Subset Definition

OBJECT			REQUEST		RESPONSE			NOTES
Obj	Var	Description	Func Codes	Qual Codes (hex)	Func Codes	Qual Codes (hex)	Data Size (bits)	
1	0	Binary Input: All Variations	1	06			1	Master will generate this variation
	1	Binary Input	1	06	129, 130	00, 01	1	Master will generate and process this variation
	2	Binary Input with Status	1	06	129, 130	00, 01	8	Master will generate and process this variation. Status flags are discarded.
2	0	Binary Input Change: All Variations	1	06, 07, 08			56	Master will generate this variation
	1	Binary Input Change Without Time	1	06, 07, 08	129, 130	17, 28	8	Master will generate and process this variation. Status flags are discarded.
	2	Binary Input Change With Time	1	06, 07, 08	129, 130	17, 28	56	Master will generate and process this variation. Status flags and time stamp are discarded.
	3	Binary Input Change With Relative Time	1	06, 07, 08	129, 130	17, 28	24	Master will generate and process this variation. Status flags and relative time are discarded.
10	0	Binary Output: All Variations	1	06			8	Master does not use this object type and will not generate a message or process this type
	1	Binary Output					1	
	2	Binary Output Status			129, 130	00, 01	8	
12	0	Control Block: All Variations					88	
	1	Control Relay Output Block	3, 4, 5, 6	17, 28	129	Echo of request	88	Master will generate this variation and parse the response
	2	Pattern Control Block					88	
	3	Pattern Mask					16	
20	0	Binary Counter: All Variations	1, 7, 8, 9, 10	06			32	Master will generate this variation
	1	32-Bit Binary Counter			129, 130	00, 01	40	Master will process this variation. Status flags are discarded.
	2	16-Bit Binary Counter			129, 130	00, 01	24	Master will process this variation
	3	32-Bit Delta Counter			129, 130	00, 01	40	Master will process this variation. Status flags are discarded.
	4	16-Bit Delta Counter			129, 130	00, 01	24	Master will process this variation
	5	32-Bit Binary Counter Without Flag	1, 7, 8, 9, 10	06		129, 130	00, 01	32

OBJECT		REQUEST		RESPONSE				NOTES
Obj	Var	Description	Func Codes	Qual Codes (hex)	Func Codes	Qual Codes (hex)	Data Size (bits)	
6		16-Bit Binary Counter Without Flag	1, 7, 8, 9, 10	06	129, 130	00, 01	16	Master will generate and process this variation
7		32-Bit Delta Counter Without Flag			129, 130	00, 01	32	Master will process this variation
8		16-Bit Delta Counter Without Flag			129, 130	00, 01	16	Master will process this variation
21	0	Frozen Counter: All Variations	1	06			32	Master will generate this variation
	1	32-Bit Frozen Counter			129, 130	00, 01	40	Master will process this variation. Status flags are discarded.
	2	16-Bit Frozen Counter			129, 130	00, 01	24	Master will process this variation. Status flags are discarded.
	3	32-Bit Frozen Delta Counter					40	
	4	16-Bit Frozen Delta Counter					24	
	5	32-Bit Frozen Counter With Time Of Freeze					88	
	6	16-Bit Frozen Counter With Time Of Freeze					72	
	7	32-Bit Frozen Delta Counter With Time Of Freeze					88	
	8	16-Bit Frozen Delta Counter With Time Of Freeze					72	
	9	32-Bit Frozen Counter Without Flag	1	06	129, 130	00, 01	32	Master will generate and process this variation
	10	16-Bit Frozen Counter Without Flag	1	06	129, 130	00, 01	16	Master will generate and process this variation
	11	32-Bit Frozen Delta Counter Without Flag					32	
	12	16-Bit Frozen Delta Counter Without Flag					16	
22	0	Counter Change Event: All Variations	1	06, 07, 08				Master will not generate a request for this variation



OBJECT		REQUEST	RESPONSE					
Obj	Var	Description	Func Codes	Qual Codes (hex)	Func Codes	Qual Codes (hex)	Data Size (bits)	NOTES
	1	32-Bit Counter Change Event Without Time			129, 130	17, 28	40	Master will process this variation. Status flags are discarded.
	2	16-Bit Counter Change Event Without Time			129, 130	17, 28	24	Master will process this variation. Status flags are discarded.
	3	32-Bit Delta Counter Change Event Without Time					40	
	4	16-Bit Delta Counter Change Event Without Time					24	
	5	32-Bit Counter Change Event With Time					88	
	6	16-Bit Counter Change Event With Time					72	
	7	32-Bit Delta Counter Change Event With Time					88	
	8	16-Bit Delta Counter Change Event With Time					72	
23	0	Frozen Counter Event: All Variations						
	1	32-Bit Frozen Counter Event Without Time					40	
	2	16-Bit Frozen Counter Event Without Time					24	
	3	32-Bit Frozen Delta Counter Event Without Time					40	
	4	16-Bit Frozen Delta Counter Event Without Time					24	
	5	32-Bit Frozen Counter Event With Time					88	
	6	16-Bit Frozen Counter Event With Time					72	
	7	32-Bit Frozen Delta Counter Event With Time					88	

OBJECT		REQUEST		RESPONSE				NOTES
Obj	Var	Description	Func Codes	Qual Codes (hex)	Func Codes	Qual Codes (hex)	Data Size (bits)	
	8	16-Bit Frozen Delta Counter Event With Time					72	
30	0	Analog Input: All Variations	1	06			16	Master will generate this variation
	1	32-Bit Analog Input	1	06	129, 130	00, 01	40	Master will generate and process this variation. Data returned will be least significant 16 bits. Status flag will be discarded.
	2	16-Bit Analog Input	1	06	129, 130	00, 01	24	Master will generate and process this variation. Status flag will be discarded.
	3	32-Bit Analog Input Without Flag	1	06	129, 130	00, 01	32	Master will generate and process this variation. Data returned will be least significant 16 bits.
	4	16-Bit Analog Input Without Flag	1	06	129, 130	00, 01	16	Master will generate and process this variation
31	0	Frozen Analog Input: All Variations						
	1	32-Bit Frozen Analog Input					40	
	2	16-Bit Frozen Analog Input					24	
	3	32-Bit Frozen Analog Input With Time To Freeze					88	
	4	16-Bit Frozen Analog Input With Time To Freeze					72	
	5	32-Bit Frozen Analog Input Without Flag					32	
	6	16-Bit Frozen Analog Input Without Flag					16	
32	0	Analog Change Event: All Variations	1	06, 07, 08			24	Master will generate this variation
	1	32-Bit Analog Change Event Without Time	1	06, 07, 08	129, 130	17, 28	40	Master will generate and process this variation. Data returned will be least significant 16 bits. Status flag will be discarded.
	2	16-Bit Analog Change Event Without Time	1	06, 07, 08	129, 130	17, 28	24	Master will generate and process this variation. Status flags are discarded.

OBJECT		REQUEST		RESPONSE			Data Size (bits)	NOTES
Obj	Var	Description	Func Codes	Qual Codes (hex)	Func Codes	Qual Codes (hex)		
	3	32-Bit Analog Change Event With Time	1	06, 07, 08	129, 130	17, 28	88	Master will generate and process this variation. Data returned will be least significant 16 bits. Time value not stored in database. Status flags are discarded.
	4	16-Bit Analog Change Event With Time	1	06, 07, 08	129, 130	17, 28	72	Master will generate and process this variation. Time value not stored in database. Status flags are discarded.
33	0	Frozen Analog Event: All Variations						
	1	32-Bit Frozen Analog Event Without Time					40	
	2	16-Bit Frozen Analog Event Without Time					24	
	3	32-Bit Frozen Analog Event With Time					88	
	4	16-Bit Frozen Analog Event With Time					72	
40	0	Analog Output Status: All Variations	1	06			24	Master does not use this object type and will not generate a message or process this type
	1	32-Bit Analog Output Status					40	
	2	16-Bit Analog Output Status			129, 130	00, 01	24	
41	0	Analog Output Block: All Variations					24	
	1	32-Bit Analog Output Block					40	
	2	16-Bit Analog Output Block	3, 4, 5, 6	17, 28	129	Echo of Request	24	Master will generate this variation and parse the response
50	0	Time and Date: All Variations					48	
	1	Time and Date	2	07, With Quant=1			48	Master will generate this variation
	2	Time and Date With Interval					80	
51	0	Time and Date CTO: All Variations						
	1	Time and Date CTO			129, 130	07, With Quant=1	48	Master will process this variation

OBJECT		REQUEST		RESPONSE				NOTES
Obj	Var	Description	Func Codes	Qual Codes (hex)	Func Codes	Qual Codes (hex)	Data Size (bits)	
	2	Unsynchronized Time and Date CTO			129, 130	07, With Quant=1	48	Master will process this variation
52	0	Time Delay: All Variations						
	1	Time Delay Coarse			129	07, With Quant=1	16	Master will not process this variation
	2	Time Delay Fine			129	07, With Quant=1	16	Master will not process this variation
60	0	Not Defined						Not Defined in DNP
	1	Class 0 Data	1	06				Master will generate this variation
	2	Class 1 Data	1	06, 07, 08				Master will generate this variation
	3	Class 2 Data	1	06, 07, 08				Master will generate this variation
	4	Class 3 Data	1	06, 07, 08				Master will generate this variation
70	0	Not Defined						
	1	File Identifier						
80	0	Not Defined						
	1	Internal Indications	2	00, Index=7			24	The Master will generate this variation
81	0	Not Defined						
	1	Storage Object						
82	0	Not Defined						
	1	Device Profile						
83	0	Not Defined						Not Defined in DNP
	1	Private Registration Object						
	2	Private Registration Objection Descriptor						
90	0	Not Defined						Not Defined in DNP
	1	Application Identifier						
100	0							
	1	Short Floating Point					48	
	2	Long Floating Point					80	
	3	Extended Floating Point					88	
101	0							
	1	Small Packed Binary-Coded Decimal					16	

OBJECT			REQUEST		RESPONSE			NOTES
Obj	Var	Description	Func Codes	Qual Codes (hex)	Func Codes	Qual Codes (hex)	Data Size (bits)	
2		Medium Packed Binary-Coded Decimal					32	
3		Large Packed Binary-Coded Decimal					64	
No Object			13					Master supports the Cold Restart Function
			14					Master supports the Warm Restart Function
			20					Master supports the Enable Unsolicited Function
			21					Master supports the Disable Unsolicited Function

#### 6.4 Command List Entry Form

	0	1	2	3	4	5	6	7	8
#	Port/Flags	Slave Add.	Object	Variation	Function	Address	Pnt Count	IED DB	Poll Interval
0									
1									
2									
3									
4									
5									
6									
7									
8									
9									
10									
11									
12									

	0	1	2	3	4	5	6	7	8
#	Port/Flags	Slave Add.	Object	Variation	Function	Address	Pnt Count	IED DB	Poll Interval
13									
14									
15									
16									
17									
18									
19									
20									
21									
22									
23									
24									
25									
26									
27									
28									
29									
30									
31									
32									
33									
34									
35									
36									

	0	1	2	3	4	5	6	7	8
#	Port/Flags	Slave Add.	Object	Variation	Function	Address	Pnt Count	IED DB	Poll Interval
37									
38									
39									
40									
41									
42									
43									
44									
45									
46									
47									
48									
49									





## 7 Support, Service & Warranty

### 7.1 Contacting Technical Support

ProSoft Technology, Inc. is committed to providing the most efficient and effective support possible. Before calling, please gather the following information to assist in expediting this process:

- 1 Product Version Number
- 2 System architecture
- 3 Network details

If the issue is hardware related, we will also need information regarding:

- 1 Module configuration and associated ladder files, if any
- 2 Module operation and any unusual behavior
- 3 Configuration/Debug status information
- 4 LED patterns
- 5 Details about the interfaced serial, Ethernet or Fieldbus devices

**Note:** For technical support calls within the United States, ProSoft's 24/7 after-hours phone support is available for urgent plant-down issues.

North America (Corporate Location)	Europe / Middle East / Africa Regional Office
Phone: +1.661.716.5100 info@prosoft-technology.com Languages spoken: English, Spanish REGIONAL TECH SUPPORT support@prosoft-technology.com	Phone: +33.(0)5.34.36.87.20 france@prosoft-technology.com Languages spoken: French, English REGIONAL TECH SUPPORT support.emea@prosoft-technology.com
Latin America Regional Office	Asia Pacific Regional Office
Phone: +52.222.264.1814 latinam@prosoft-technology.com Languages spoken: Spanish, English REGIONAL TECH SUPPORT support.la@prosoft-technology.com	Phone: +60.3.2247.1898 asiapc@prosoft-technology.com Languages spoken: Bahasa, Chinese, English, Japanese, Korean REGIONAL TECH SUPPORT support.ap@prosoft-technology.com

For additional ProSoft Technology contacts in your area, please visit:  
<https://www.prosoft-technology.com/About-Us/Contact-Us>.

### 7.2 Warranty Information

For complete details regarding ProSoft Technology's TERMS & CONDITIONS OF SALE, WARRANTY, SUPPORT, SERVICE AND RETURN MATERIAL AUTHORIZATION INSTRUCTIONS, please see the documents at: [www.prosoft-technology.com/legal](http://www.prosoft-technology.com/legal)