



Where Automation Connects.



ProTalk[®]

PTQ-WA-PWP

Quantum / Unity Platform

Wireless Communication Module

2/2/2009

USER MANUAL

Warnings

North America Warnings

- A** Warning - Explosion Hazard - Substitution of components may impair suitability for Class I, Division 2.
- B** Warning - Explosion Hazard - When in Hazardous Locations, turn off power before replacing or rewiring modules.
Warning - Explosion Hazard - Do not disconnect equipment unless power has been switched off or the area is known to be nonhazardous.
- C** Suitable for use in Class I, division 2 Groups A, B, C and D Hazardous Locations or Non-Hazardous Locations.

ATEX Warnings and Conditions of Safe Usage:

Power, Input, and Output (I/O) wiring must be in accordance with the authority having jurisdiction

- A** Warning - Explosion Hazard - When in hazardous locations, turn off power before replacing or wiring modules.
- B** Warning - Explosion Hazard - Do not disconnect equipment unless power has been switched off or the area is known to be non-hazardous.
- C** These products are intended to be mounted in an IP54 enclosure. The devices shall provide external means to prevent the rated voltage being exceeded by transient disturbances of more than 40%. This device must be used only with ATEX certified backplanes.
- D** DO NOT OPEN WHEN ENERGIZED.

Electrical Ratings

- Backplane Current Load: 800 mA @ 5 V DC; 3mA @ 24V DC
- Operating Temperature: 0 to 60°C (32 to 140°F)
- Storage Temperature: -40 to 85°C (-40 to 185°F)
- Shock: 30g Operational; 50g non-operational; Vibration: 5 g from 10 to 150 Hz
- Relative Humidity 5% to 95% (non-condensing)
- All phase conductor sizes must be at least 1.3 mm(squared) and all earth ground conductors must be at least 4mm(squared).

Markings:

ISA	ISA 12.12.01 Class 1 Div 2
CSA/cUL	C22.2 No. 213-1987



243333

Information for ProTalk® Product Users

The statement "power, input and output (I/O) wiring must be in accordance with Class I, Division 2 wiring methods Article 501-10(b) of the National Electrical Code, NFPA 70 for installations in the U.S., or as specified in section 18-1J2 of the Canadian Electrical Code for installations within Canada and in accordance with the authority having jurisdiction".

The following or equivalent warnings shall be included:

- A** Warning - Explosion Hazard - Substitution of components may Impair Suitability for Class I, Division 2;
- B** Warning - Explosion Hazard - When in Hazardous Locations, Turn off Power before replacing Wiring Modules, and
- C** Warning - Explosion Hazard - Do not Disconnect Equipment unless Power has been switched Off or the Area is known to be Nonhazardous.
- D** Caution: The Cell used in this Device may Present a Fire or Chemical Burn Hazard if Mistreated. Do not Disassemble, Heat above 100°C (212°F) or Incinerate.

WARNING – EXPLOSION HAZARD – DO NOT DISCONNECT EQUIPMENT UNLESS POWER HAS BEEN SWITCHED OFF OR THE AREA IS KNOWN TO BE NON-HAZARDOUS.
AVERTISSEMENT – RISQUE D'EXPLOSION – AVANT DE DÉCONNECTER L'EQUIPMENT, COUPER LE COURANT OU S'ASSURER QUE L'EMPLACEMENT EST DÉSIGNÉ NON DANGEREUX.

CL I Div 2 GP A, B, C, D

Temp Code T5

II 3 G

Ex nA nL IIC T4 X

0° C <= Ta <= 60° C

II – Equipment intended for above ground use (not for use in mines).

3 – Category 3 equipment, investigated for normal operation only.

G – Equipment protected against explosive gasses.

Important Notice:



CAUTION: THE CELL USED IN THIS DEVICE MAY PRESENT A FIRE OR CHEMICAL BURN HAZARD IF MISTREATED. DO NOT DISASSEMBLE, HEAT ABOVE 100°C (212°F) OR INCINERATE.

Maximum battery load = 200 µA.

Maximum battery charge voltage = 3.4 VDC.

Maximum battery charge current = 500 µA.

Maximum battery discharge current = 30 µA.

Important Installation Instructions: Radio Modules

The following Information and warnings pertaining to the radio module must be heeded:

- A** "THIS DEVICE CONTAINS A TRANSMITTER MODULE, FCC ID: SDZ-WA-1. PLEASE SEE FCC ID LABEL ON BACK OF DEVICE."
- B** "THIS DEVICE USES AN INTERNAL COMPACT FLASH RADIO MODULE AS THE PRIMARY RADIO COMPONENT. THE COMPACT FLASH RADIO MODULE DOES NOT HAVE AN FCC ID LABEL. THE COMPACT FLASH RADIO MODULE HAS NO USER SERVICABLE PARTS."
- C** "THIS DEVICE COMPLIES WITH PART 15 OF THE FCC RULES. OPERATION IS SUBJECT TO THE FOLLOWING TWO CONDITIONS: (1) THIS DEVICE MAY NOT CAUSE HARMFUL INTERFERENCE, AND (2) THIS DEVICE MUST ACCEPT ANY INTERFERENCE RECEIVED, INCLUDING INTERFERENCE THAT MAY CAUSE UNDESIRE OPERATION."
- D** "THIS DEVICE AND ANY RADIO ACCESSORY SOLD BY PROSOFT MUST BE INSTALLED BY AN AUTHORIZED PROFESSIONAL INDUSTRIAL RADIO SYSTEM INTEGRATOR. FURTHER, ONLY RADIO ACCESSORIES SOLD BY PROSOFT AND SPECIFICALLY TESTED FOR USE WITH THIS DEVICE MAY BE USED WITH THIS DEVICE."
- E** "THE USER OF THIS EQUIPMENT CANNOT BE WITHIN 20 cm. FROM THE RADIATING ELEMENT DEVICE."
- F** "CHANGES OR MODIFICATIONS NOT EXPRESSLY APPROVED BY THE PARTY RESPONSIBLE FOR COMPLIANCE COULD VOID THE USER'S AUTHORITY TO OPERATE THE EQUIPMENT."

Industry Canada Requirements:

- A** "THIS DEVICE HAS BEEN DESIGNED TO OPERATE WITH AN ANTENNA HAVING A MAXIMUM GAIN OF 24 dB. AN ANTENNA HAVING A HIGHER GAIN IS STRICTLY PROHIBITED PER REGULATIONS OF INDUSTRY CANADA. THE REQUIRED ANTENNA IMPEDANCE IS 50 OHMS."
- B** "TO REDUCE POTENTIAL RADIO INTERFERENCE TO OTHER USERS, THE ANTENNA TYPE AND ITS GAIN SHOULD BE CHOSEN SUCH THAT THE EQUIVALENT ISOTROPICALLY RADIATED POWER (EIRP) IS NOT MORE THAN THAT REQUIRED FOR SUCCESSFUL COMMUNICATION."
- C** "THE INSTALLER OF THIS RADIO EQUIPMENT MUST INSURE THAT THE ANTENNA IS LOCATED OR POINTED SUCH THAT IT DOES NOT EMIT RF FIELD IN EXCESS OF HEALTH CANADA LIMITS FOR THE GENERAL POPULATION; CONSULT SAFETY CODE 6, OBTAINABLE FROM HEALTH CANADA."

WARNING:

This is a Class A product. In a domestic environment this product may cause radio interference in which case the user may be required to take adequate measures.

Your Feedback Please

We always want you to feel that you made the right decision to use our products. If you have suggestions, comments, compliments or complaints about the product, documentation or support, please write or call us.

ProSoft Technology

1675 Chester Avenue, Fourth Floor

Bakersfield, CA 93301

+1 (661) 716-5100

+1 (661) 716-5101 (Fax)

<http://www.prosoft-technology.com>

Copyright © ProSoft Technology, Inc. 2009. All Rights Reserved.

PTQ-WA-PWP User Manual

2/2/2009

ProSoft Technology®, ProLinx®, inRAx®, ProTalk® and RadioLinx® are Registered Trademarks of ProSoft Technology, Inc.

Contents

Warnings	2
Information for ProTalk® Product Users	2
Important Notice:	3
Important Installation Instructions: Radio Modules	3
Your Feedback Please	4
Guide to the PTQ-WA-PWP User Manual	7
<hr/>	
1 Start Here	9
<hr/>	
1.1 Hardware and Software Requirements	9
1.2 Install ProSoft Configuration Builder Software	11
2 Configuring the Processor with Concept	13
<hr/>	
2.1 Information for Concept Version 2.6 Users	14
2.2 Create a New Project	15
2.3 Add the PTQ Module to the Project	18
2.4 Set up Data Memory in Project	20
2.5 Download the Project to the Processor	23
2.6 Verify Successful Download	26
3 Configuring the Processor with ProWORX	31
<hr/>	
4 Configuring the Processor with UnityPro XL	35
<hr/>	
4.1 Create a New Project	35
4.2 Add the PTQ Module to the Project	37
4.3 Build the Project	39
4.4 Connect Your PC to the Processor	40
4.5 Download the Project to the Processor	42
5 Setting Up the ProTalk Module	43
<hr/>	
5.1 Install the ProTalk Module in the Quantum Rack	43
5.2 Connect the PC to the ProTalk Configuration/Debug Port	44
5.3 Verify Communication Between the Processor and the Module	46
5.4 ProSoft Configuration Builder	47
5.5 [Backplane Configuration]	53
5.6 [Radio Configuration]	54
5.7 [Radio SNTP Client]	55
5.8 [RADIO PWP Exchanges]	57
5.9 [Radio PWP Multicast Group List]	61
5.10 Radio Ethernet Configuration	61

6	Verify Radio Communications	65
6.1	Save and Download the Configuration File to the PTQ-WA-PWP	65
6.2	Save and Download the Configuration File to the 6104-WA-PDPM	67
6.3	Verify Data Exchange	68
7	Diagnostics and Troubleshooting	71
7.1	Reading Status Data from the Module	71
7.2	LED Status Indicators	83
8	Reference	87
8.1	Product Specifications	87
8.2	Functional Overview	89
8.3	RS-232 Configuration/Debug Port	99
8.4	PWP Error/Status Data	100
8.5	Exchange Configuration Form	101
9	Support, Service & Warranty	103
9.1	How to Contact Us: Technical Support.....	103
9.2	Return Material Authorization (RMA) Policies and Conditions	104
9.3	LIMITED WARRANTY	105
Index		111

Guide to the PTQ-WA-PWP User Manual

Function		Section to Read	Details
Introduction (Must Do)	→	Start Here (page 9)	This Section introduces the customer to the module. Included are: package contents, system requirements, hardware installation, and basic configuration.
Verify Communication, Diagnostic and Troubleshooting	→	Verifying Communication (page 65) Diagnostics and Troubleshooting (page 71)	This section describes how to verify communications with the network. Diagnostic and Troubleshooting procedures.
Reference Product Specifications Functional Overview Glossary	→	Reference (page 87) Functional Overview (page 89) Product Specifications (page 87)	These sections contain general references associated with this product, Specifications, and the Functional Overview.
Support, Service, and Warranty Index	→	Support, Service and Warranty (page 103)	This section contains Support, Service and Warranty information. Index of chapters.

1 Start Here

In This Chapter

- ❖ Hardware and Software Requirements 9
- ❖ Install ProSoft Configuration Builder Software..... 11

This guide is intended to guide you through the ProTalk module setup process, from removing the module from the box to exchanging data with the processor. In doing this, you will learn how to:

- Set up the processor environment for the PTQ module
- View how the PTQ module exchanges data with the processor
- Edit and download configuration files from your PC to the PTQ module
- Monitor the operation of the PTQ module

1.1 Hardware and Software Requirements

1.1.1 ProTalk Module Carton Contents

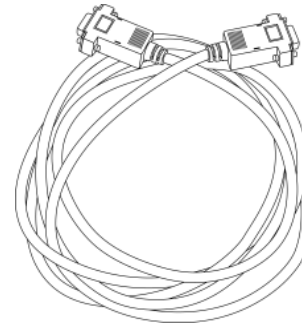

ProTalk Module

Null Modem Serial Cable



5dbi Omni Articulating Antenna (A2405S-OA)

ProSoft Solutions CD

Quantum / Unity Hardware

This guide assumes that you are familiar with the installation and setup of the Quantum / Unity hardware. The following should be installed, configured and powered up before proceeding:

- Quantum or Unity Processor
- Quantum rack
- Quantum power supply
- Quantum Modbus Plus Network Option Module (NOM Module) (optional)
- Quantum to PC programming hardware
- NOM Ethernet or Serial connection to PC

PC and PC Software

- Windows-based PC with at least one COM port
- Quantum programming software installed on machine
- or
- Concept™ PLC Programming Software version 2.6
- or
- ProWORX PLC Programming Software
- or
- UnityPro XL PLC Programming Software
- HyperTerminal (used in this guide) This is a communication program that is included with Microsoft Windows. You can normally find it in **Start / Programs / accessories / Communications**.

Note: ProTalk modules are compatible with common Quantum / Unity programming applications, including Concept and UnityPro XL. For all other programming applications, please contact technical support.

1.2 Install ProSoft Configuration Builder Software

You must install the ProSoft Configuration Builder (PCB) software in order to configure the PTQ-WA-PWP module. You can always get the newest version of ProSoft Configuration Builder from the ProSoft Technology web site.

To install ProSoft Configuration Builder from the ProSoft Web Site

- 1 Open your web browser and navigate to <http://www.prosoft-technology.com/pcb>
- 2 Click the **Download Here** link to download the latest version of ProSoft Configuration Builder.
- 3 Choose "Save" or "Save File" when prompted. The following illustrations show the file download prompt for two of the most common web browsers.

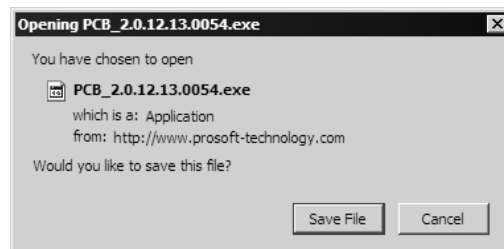

- 4 Save the file to your Desktop, so that you can find it easily when you have finished downloading.
- 5 When the download is complete, locate and open the file, and then follow the instructions on your screen to install the program.

If you do not have access to the Internet, you can install ProSoft Configuration Builder from the ProSoft Solutions CD-ROM, included in the package with your PTQ-WA-PWP module.

To install ProSoft Configuration Builder from the Product CD

- 1 Insert the ProSoft Solutions Product CD into the CD drive of your PC. Wait for the startup screen to appear.
- 2 On the startup screen, click *Product Documentation*. This action opens an explorer window.

- 3** Click to open the *Utilities* folder. This folder contains all of the applications and files you will need to set up and configure your module.
- 4** Double-click the *ProSoft Configuration Builder Setup* program and follow the instructions on your screen to install the software on your PC.

Note: Many of the configuration and maintenance procedures use files and other utilities on the CD-ROM. You may wish to copy the files from the Utilities folder on the CD-ROM to a convenient location on your hard drive.

2 Configuring the Processor with Concept

In This Chapter

- ❖ Information for Concept Version 2.6 Users..... 14
- ❖ Create a New Project 15
- ❖ Add the PTQ Module to the Project..... 18
- ❖ Set up Data Memory in Project..... 20
- ❖ Download the Project to the Processor 23
- ❖ Verify Successful Download 26

The following steps are designed to ensure that the processor is able to transfer data successfully with the PTQ module. As part of this procedure, you will use Concept configuration software from Schneider Electric to create a project, add the PTQ module to the project, set up data memory for the project, and then download the project to the processor.

Important Note: Concept software does not report whether the PTQ module is present in the rack, and therefore is not able to report the health status of the module when the module is online with the Quantum processor. Please take this into account when monitoring the status of the PTQ module.

2.1 Information for Concept Version 2.6 Users

This guide uses Concept PLC Programming Software version 2.6 to configure the Quantum PLC. The ProTalk installation CD includes MDC module configuration files that help document the PTQ installation. Although not required, these files should be installed before proceeding to the next section.

2.1.1 Installing MDC Configuration Files

- 1 From a PC with Concept 2.6 installed, choose **Start / Programs / Concept / ModConnect Tool**.

This action opens the Concept Module Installation dialog box.

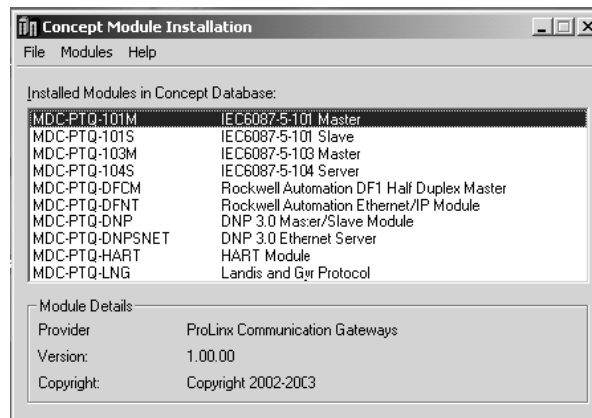

- 2 Choose **File / Open Installation File**.

This action opens the Open Installation File dialog box:

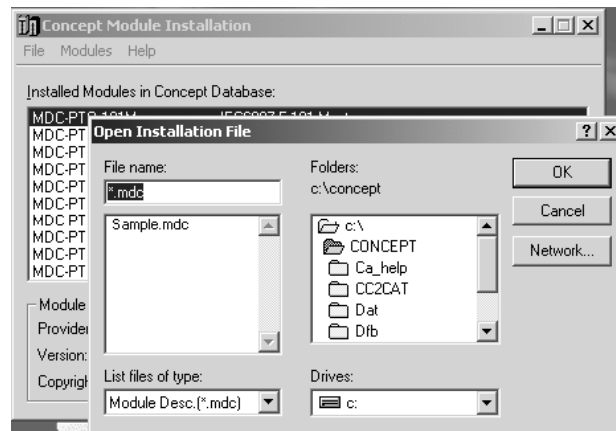

- 3 If you are using a Quantum processor, you will need the MDC files. In the Open Installation File dialog box, navigate to the **MDC Files** directory on the ProTalk CD.

- 4 Choose the MDC file and help file for your version of Concept:
 - Concept 2.6 users: select PTQ_2_60.mdc and PTQMDC.hlp
 - Concept 2.5 users: select PTQ_2_50.mdc and PTQMDC.hlp.

Select the files that go with the Concept version you are using, and then click **OK**. This action opens the add New Modules dialog box.

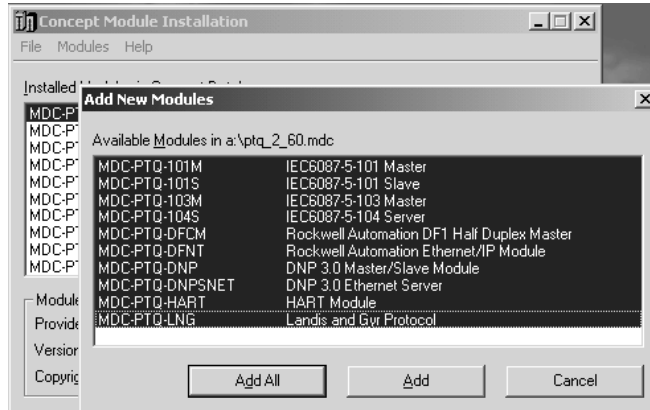

- 5 Click the **add all** button. A series of message boxes may appear during this process. Click **Yes** or **OK** for each message that appears.
- 6 When the process is complete, open the File menu and choose Exit to save your changes.

2.2 Create a New Project

This phase of the setup procedure must be performed on a computer that has the Concept configuration software installed.

- 1 From your computer, choose **Start / Programs / Concept V2.6 XL.EN / Concept**. This action opens the Concept window.

- 2 Open the File menu, and then choose **New Project**. This action opens the PLC Configuration dialog box.

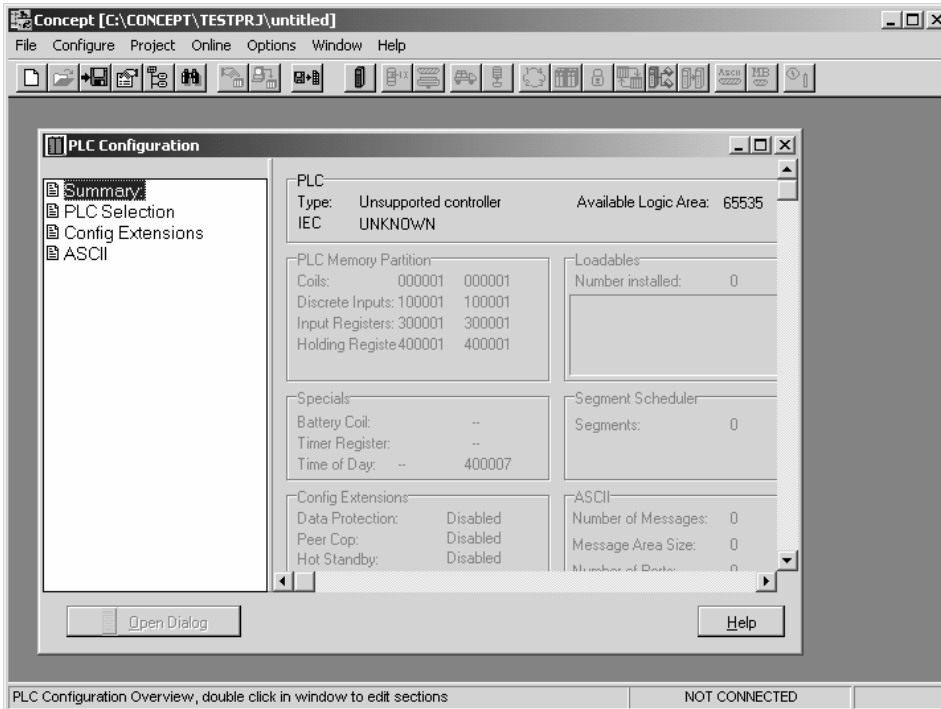

- 3 In the list of options on the left side of this dialog box, double-click the *PLC Selection* folder. This action opens the PLC Selection dialog box.

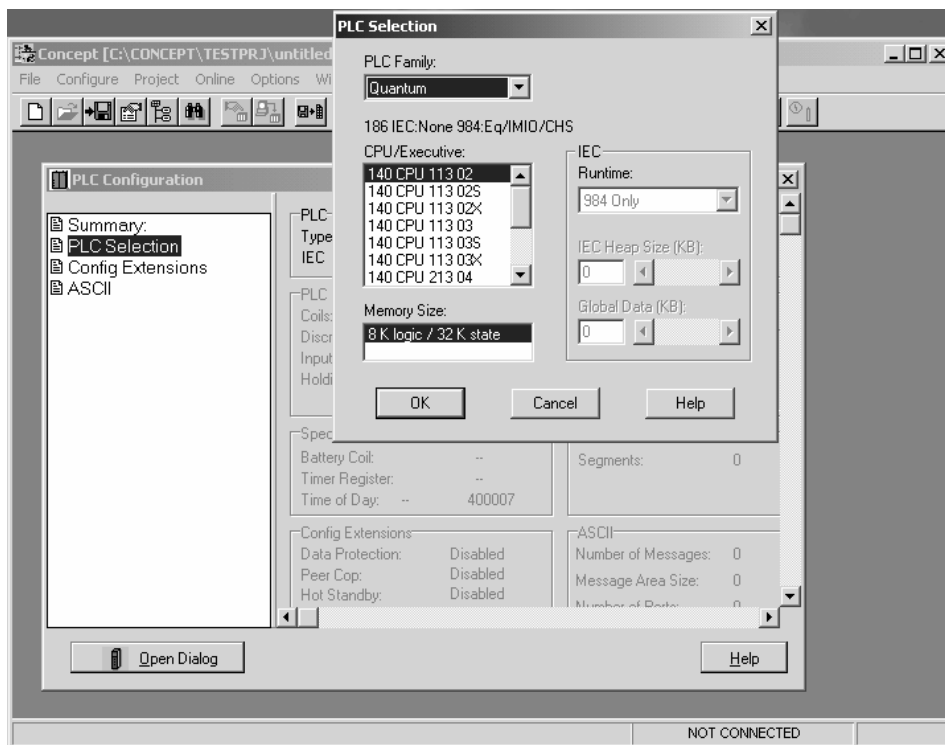

- In the *CPU/Executive* pane, use the scroll bar to locate and select the PLC to configure.

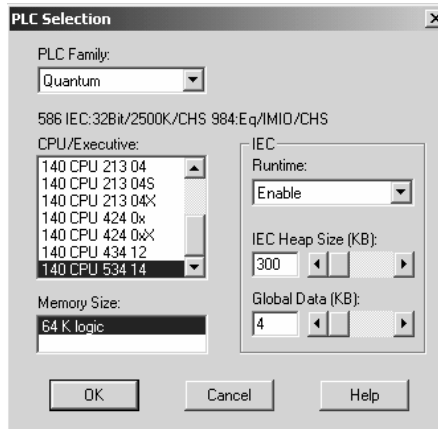

- Click **OK**. This action opens the *PLC Configuration* dialog box, populated with the correct values for the PLC you selected.



- Make a note of the holding registers for the module. You will need this information when you modify your application as outlined in the ProTalk application Reference Guides. The Holding Registers are displayed in the PLC Memory Partition pane of the PLC Configuration dialog box.

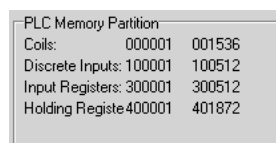

2.3 Add the PTQ Module to the Project

- 1 In the list of options on the left side of the *PLC Configuration* dialog box, double-click *I/O Map*. This action opens the *I/O Map* dialog box.

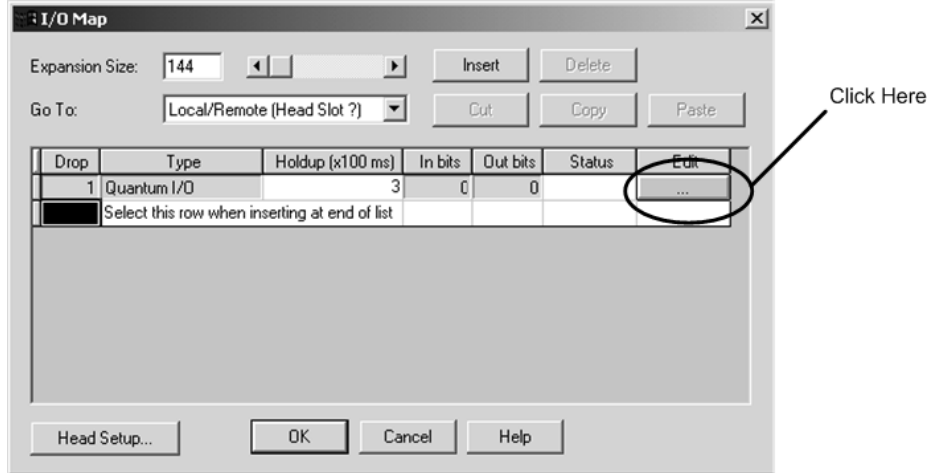

- 2 Click the **Edit** button to open the *Local Quantum Drop* dialog box. This dialog box is where you identify rack and slot locations.

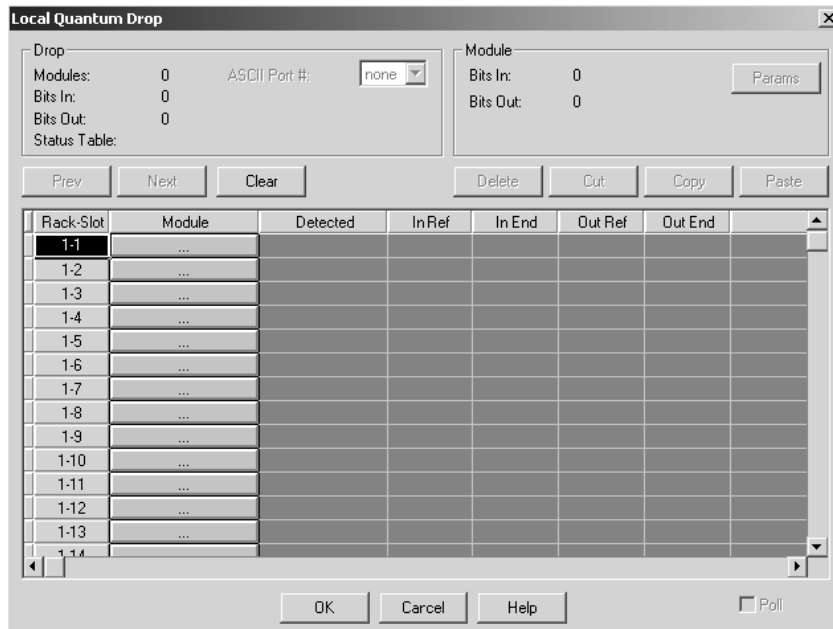

- Click the Module button next to the rack/slot position where the ProTalk module will be installed. This action opens the I/O Module Selection dialog box.

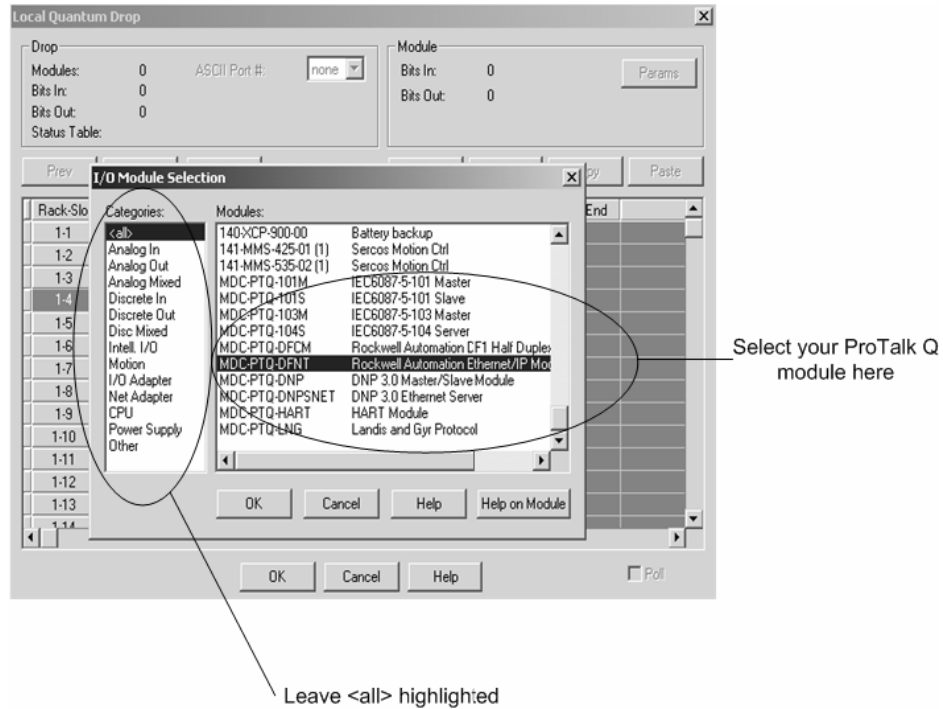

- In the Modules pane, use the scroll bar to locate and select the ProTalk module, and then click OK. This action copies the description of the ProTalk module next to the assigned rack and slot number of the Local Quantum Drop dialog box.

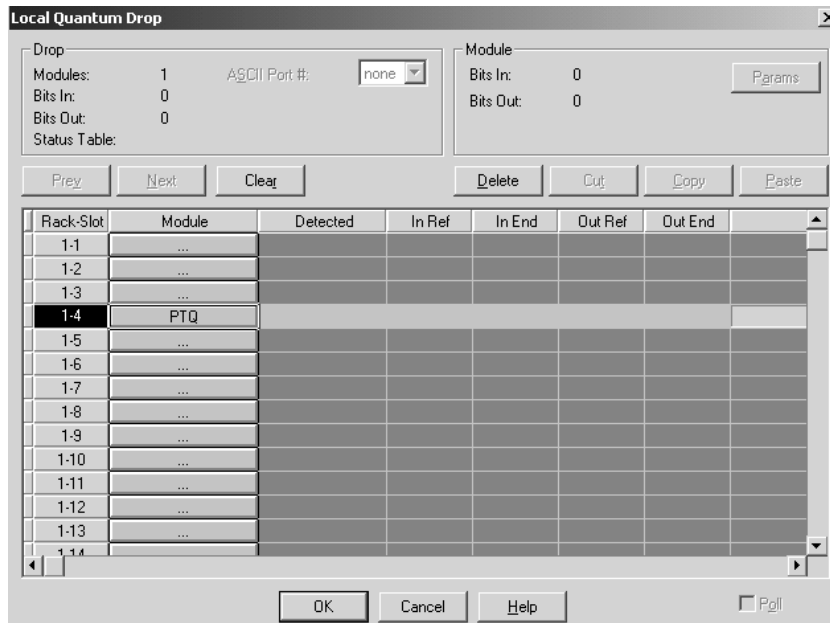

- Repeat steps 3 through 5 for each ProTalk module you plan to install. When you have finished installing your ProTalk modules, click OK to save your settings. Click Yes to confirm your settings.

Tip: Select a module, and then click the Help on Module button for help pages.

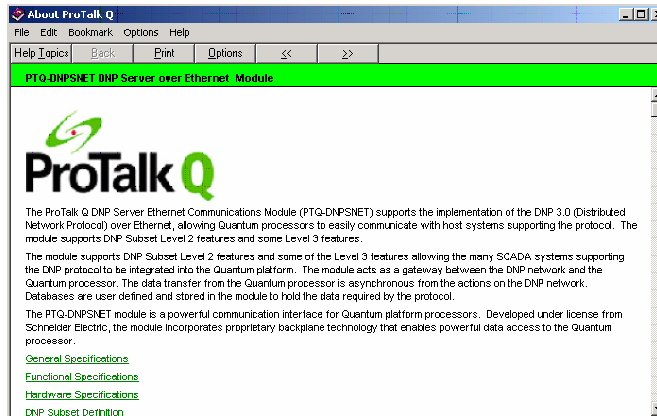

2.4 Set up Data Memory in Project

- In the list of options on the left side of the PLC Configuration dialog box, double-click Specials.

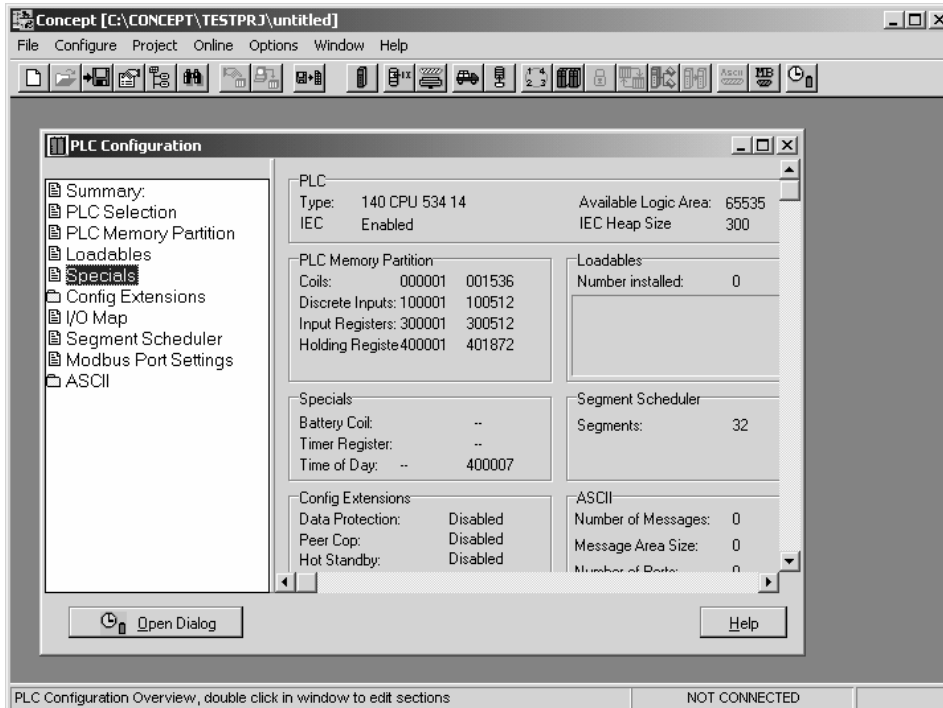

- This action opens the Specials dialog box.

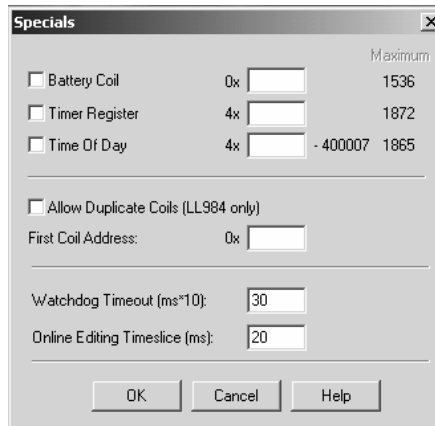

Selecting the Time of Day

- Select (check) the Time of Day box, and then enter the value 00001 as shown in the following example. This value sets the first time of day register to 400001.

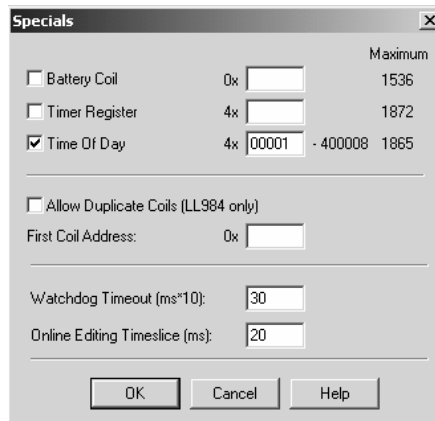

- Click OK to save your settings and close the Specials dialog box.

Saving your project

- 1 In the PLC Configuration dialog box, choose File / Save project as.

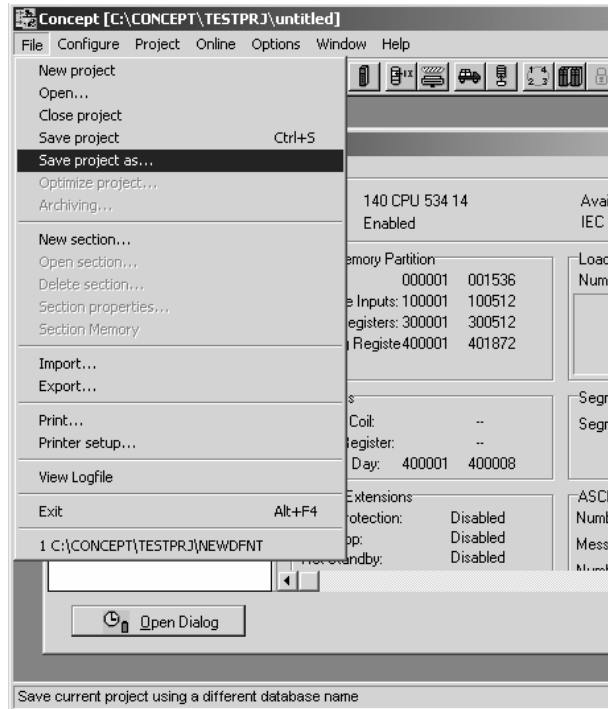

- 2 This action opens the Save Project as dialog box.

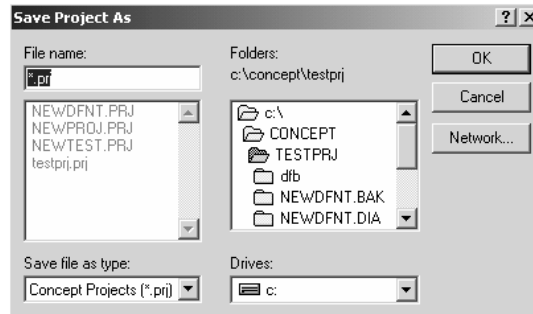

- 3 Name the project, and then click OK to save the project to a file.

2.5 Download the Project to the Processor

Next, download (copy) the project file to the Quantum Processor.

- 1 Use the null modem cable to connect your PC's serial port to the Quantum processor, as shown in the following illustration.

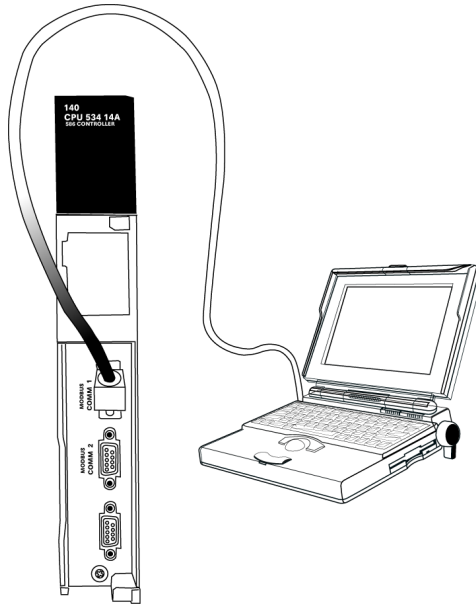

Note: You can use a Modbus Plus Network Option Module (NOM Module) module in place of the serial port if necessary.

- 2 Open the PLC menu, and then choose Connect.

- 3 In the PLC Configuration dialog box, open the Online menu, and then choose Connect. This action opens the Connect to PLC dialog box.

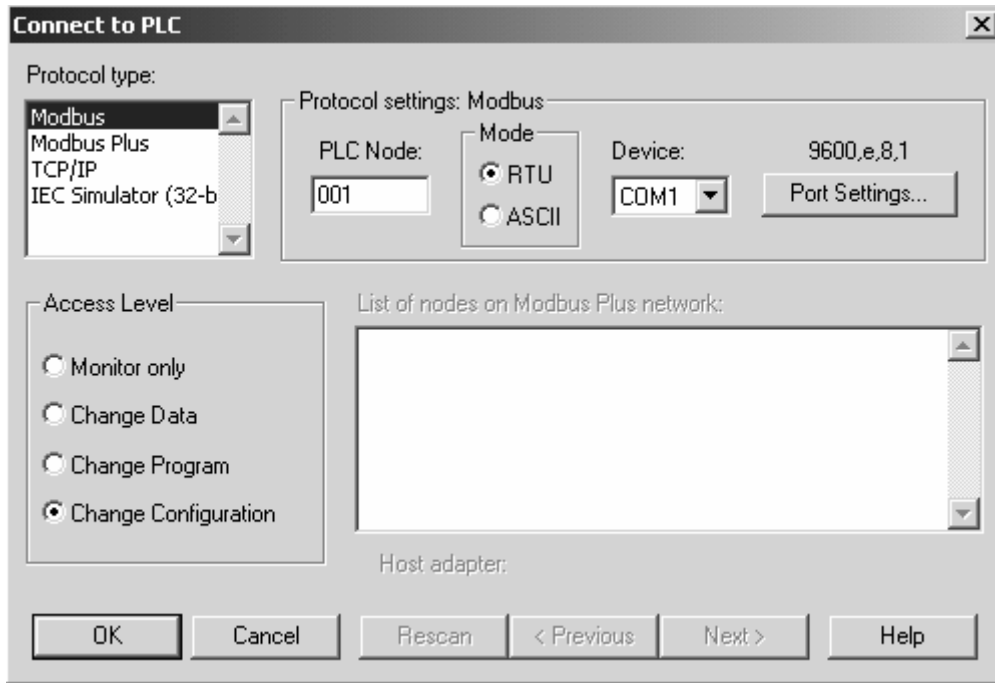

- 4 Leave the default settings as shown and click OK.

Note: Click OK to dismiss any message boxes that appear during the connection process.

- 5 In the PLC Configuration window, open the Online menu, and then choose Download. This action opens the Download Controller dialog box.



- Click all, and then click Download. If a message box appears indicating that the controller is running, click Yes to shut down the controller. The Download Controller dialog box displays the status of the download as shown in the following illustration.

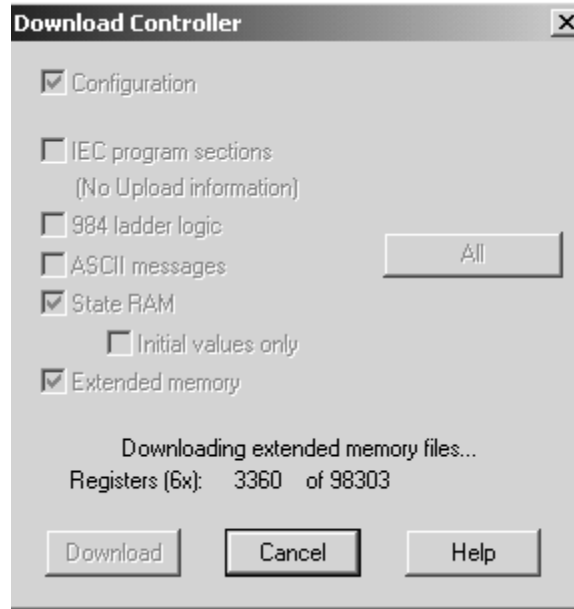

- When the download is complete, you will be prompted to restart the controller. Click Yes to restart the controller.

2.6 Verify Successful Download

The final step is to verify that the configuration changes you made were received successfully by the module, and to make some adjustments to your settings.

- 1 In the PLC Configuration window, open the Online menu, and then choose Online Control Panel. This action opens the Online Control Panel dialog box.

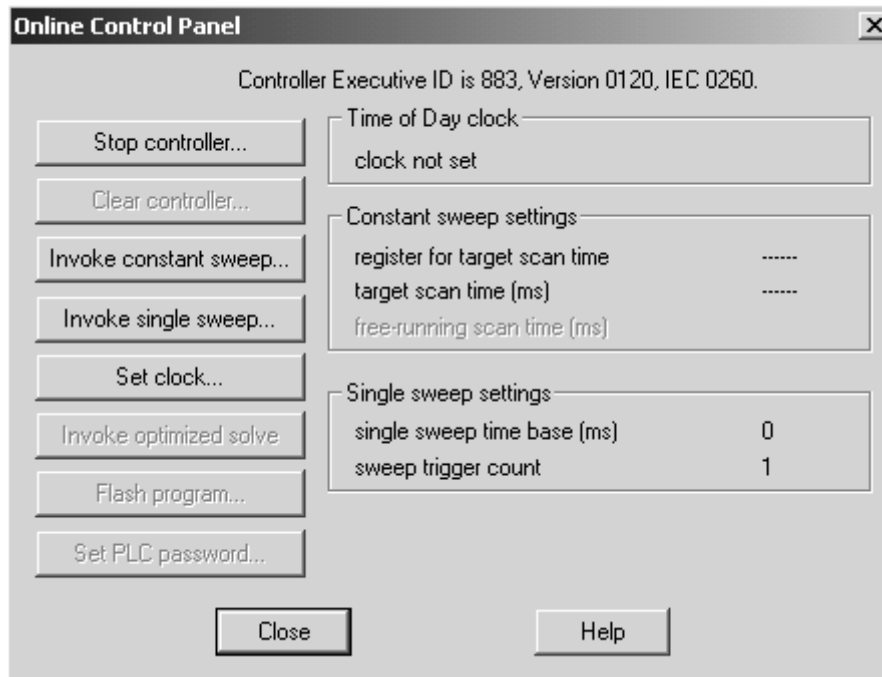

- 2 Click the Set Clock button to open the Set Controller's Time of Day Clock dialog box.

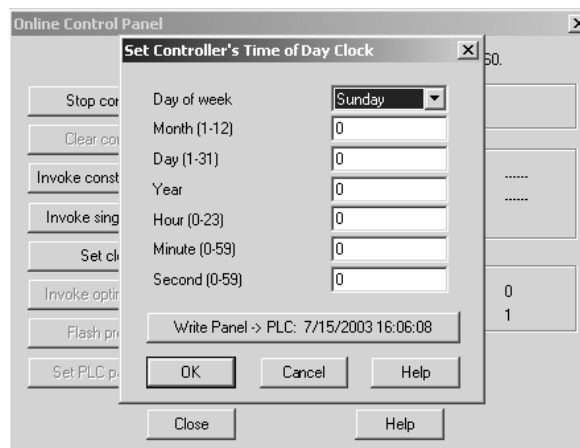

- 3 Click the Write Panel button. This action updates the date and time fields in this dialog box. Click OK to close this dialog box and return to the previous window.
- 4 Click Close to close the Online Control Panel dialog box.

- 5 In the PLC Configuration window, open the Online menu, and then choose Reference Data Editor. This action opens the Reference Data Editor dialog box. On this dialog box, you will add preset values to data registers that will later be monitored in the ProTalk module.
- 6 Place the cursor over the first address field, as shown in the following illustration.

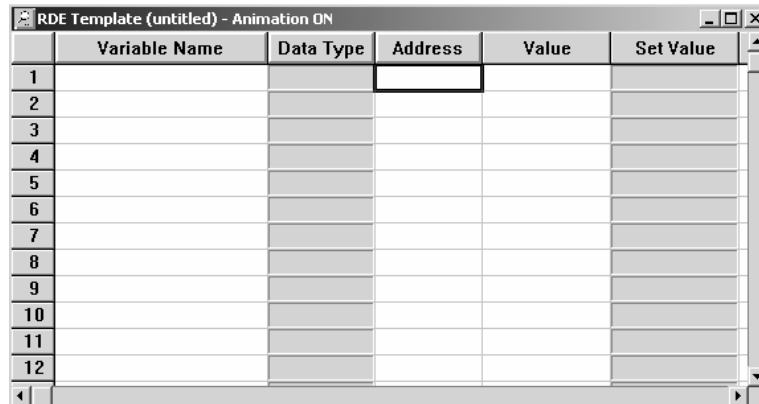

	Variable Name	Data Type	Address	Value	Set Value
1					
2					
3					
4					
5					
6					
7					
8					
9					
10					
11					
12					

- 7 In the PLC Configuration window, open the Templates menu, and then choose Insert addresses. This action opens the Insert addresses dialog box.
- 8 On the Insert addresses dialog box, enter the values shown in the following illustration, and then click OK.

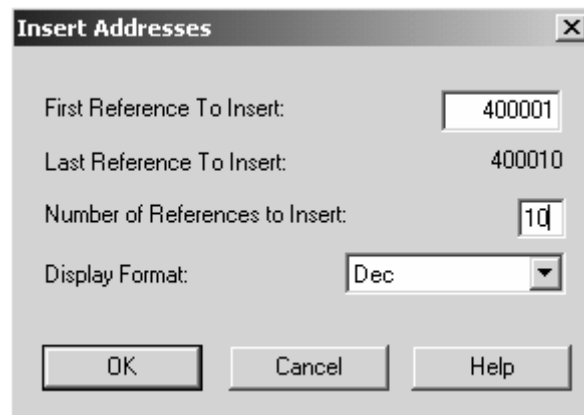

Insert Addresses

First Reference To Insert: 400001

Last Reference To Insert: 400010

Number of References to Insert: 10

Display Format: Dec

OK Cancel Help

- 9 Notice that the template populates the address range, as shown in the following illustration. Place your cursor as shown in the first blank address field below the addresses you just entered.

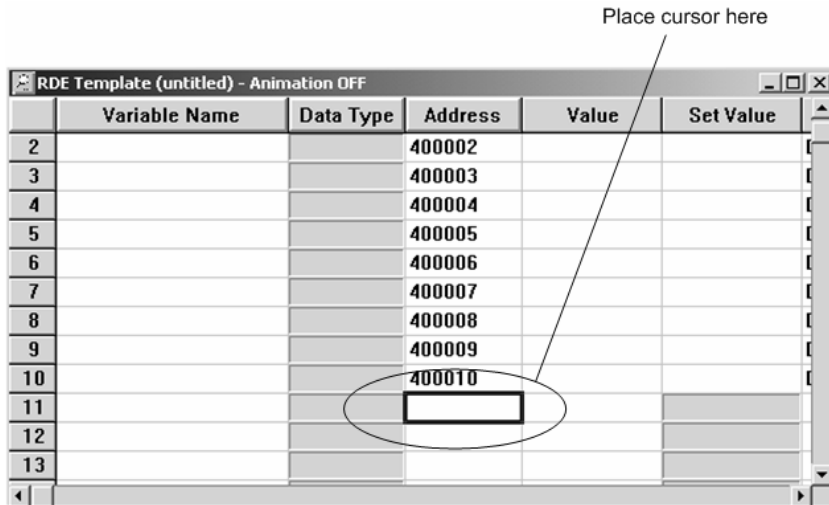

- 10 Repeat steps 6 through 9, using the values in the following illustration:

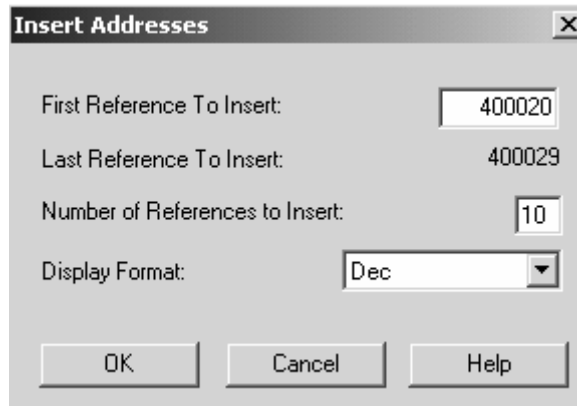

- 11** In the PLC Configuration window, open the Online menu, and then choose animate. This action opens the RDE Template dialog box, with animated values in the Value field.

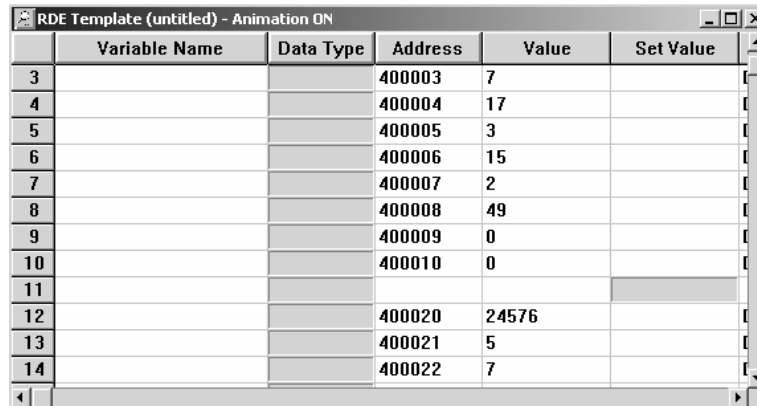

	Variable Name	Data Type	Address	Value	Set Value
3			400003	7	
4			400004	17	
5			400005	3	
6			400006	15	
7			400007	2	
8			400008	49	
9			400009	0	
10			400010	0	
11					
12			400020	24576	
13			400021	5	
14			400022	7	

- 12** Verify that values shown are cycling, starting from address 400065 on up.
- 13** In the PLC Configuration window, open the Templates menu, and then choose Save Template as. Name the template ptqclock, and then click OK to save the template.
- 14** In the PLC Configuration window, open the Online menu, and then choose Disconnect. At the disconnect message, click Yes to confirm your choice.

At this point, you have successfully

- Created and downloaded a Quantum project to the PLC
- Preset values in data registers that will later be monitored in the ProTalk module.

You are now ready to complete the installation and setup of the ProTalk module.

3 Configuring the Processor with ProWORX

When you use ProWORX 32 software to configure the processor, use the example SaF file provided on the ProTalk Solutions CD-ROM.

Important Note: Proworx software does not report whether the PTQ module is present in the rack, and therefore is not able to report the health status of the module when the module is online with the Quantum processor. Please take this into account when monitoring the status of the PTQ module.

- 1 Run the Schneider_alliances.exe application that is installed with the Proworx 32 software:



- 2 Click on Import...



- 3 Select the .SaF File that is located at the CD-ROM shipped with the PTQ module.

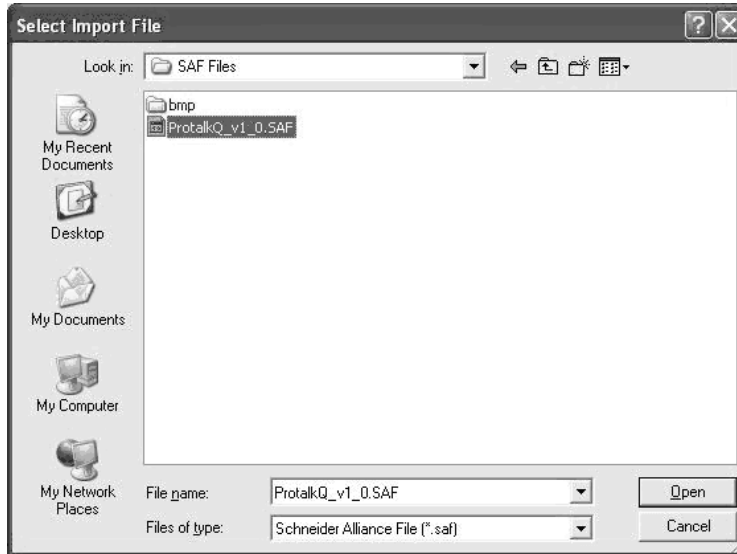

- 4 After you click on Open you should see the PTQ modules imported (select I/O series as Quantum):

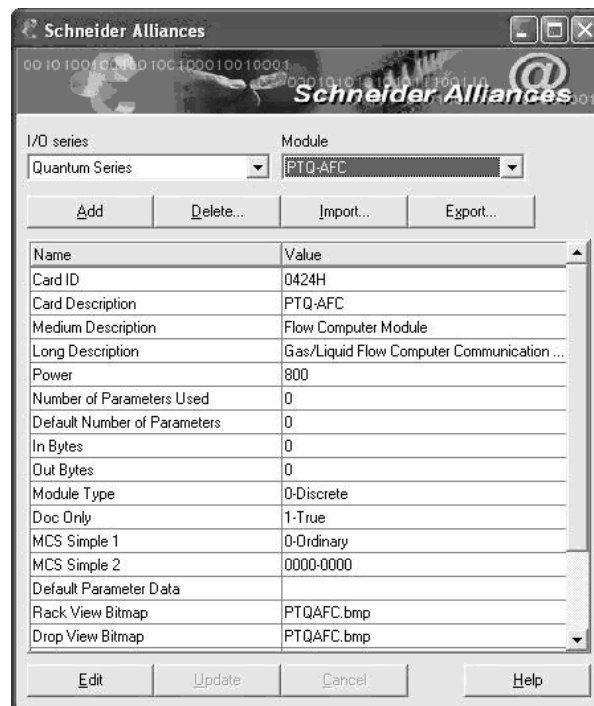

Now you can close the Schneider alliances application and run the Proworx 32 software. At the Traffic Cop section, select the PTQ module to be inserted at the slot:

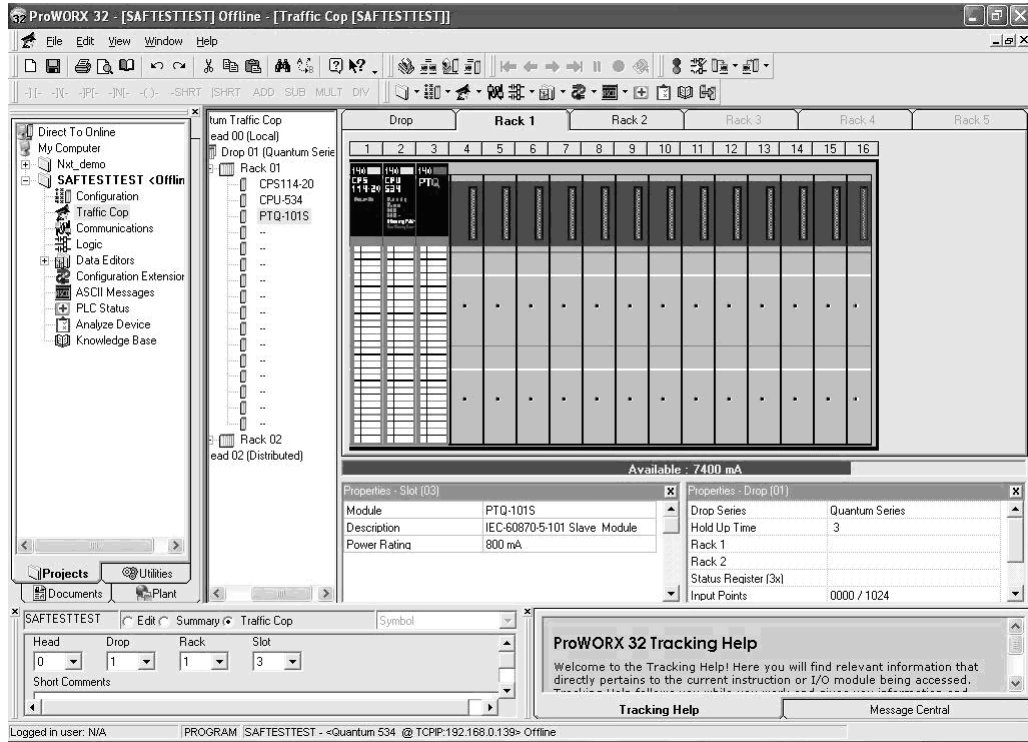

4 Configuring the Processor with UnityPro XL

In This Chapter

- ❖ Create a New Project 35
- ❖ Add the PTQ Module to the Project 37
- ❖ Build the Project 39
- ❖ Connect Your PC to the Processor 40
- ❖ Download the Project to the Processor 42

The following steps are designed to ensure that the processor (Quantum or Unity) is able to transfer data successfully with the PTQ module. As part of this procedure, you will use UnityPro XL to create a project, add the PTQ module to the project, set up data memory for the project, and then download the project to the processor.

4.1 Create a New Project

The first step is to open UnityPro XL and create a new project.

- 1 In the New Project dialog box, choose the CPU type. In the following illustration, the CPU is 140 CPU 651 60. Choose the processor type that matches your own hardware configuration, if it differs from the example. Click OK to continue.

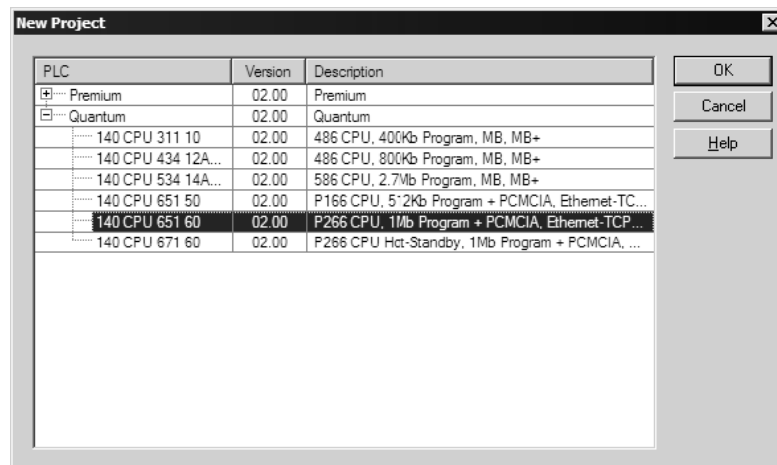

- Next, add a power supply to the project. In the Project Browser, expand the Configuration folder, and then double-click the 1:LocalBus icon. This action opens a graphical window showing the arrangement of devices in your Quantum rack.

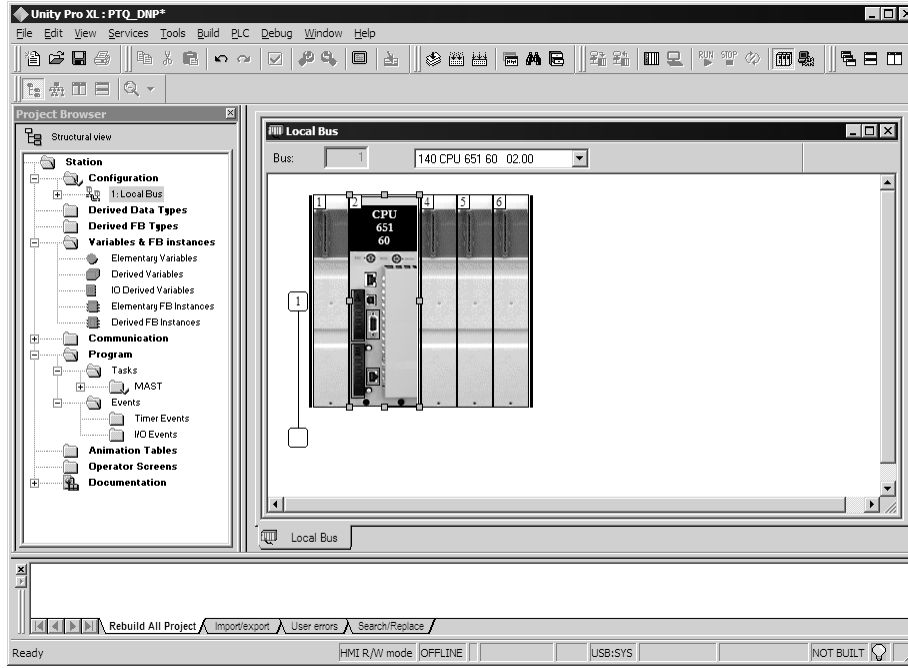

- Select the rack position for the power supply, and then click the right mouse button to open a shortcut menu. On the shortcut menu, choose New Device..

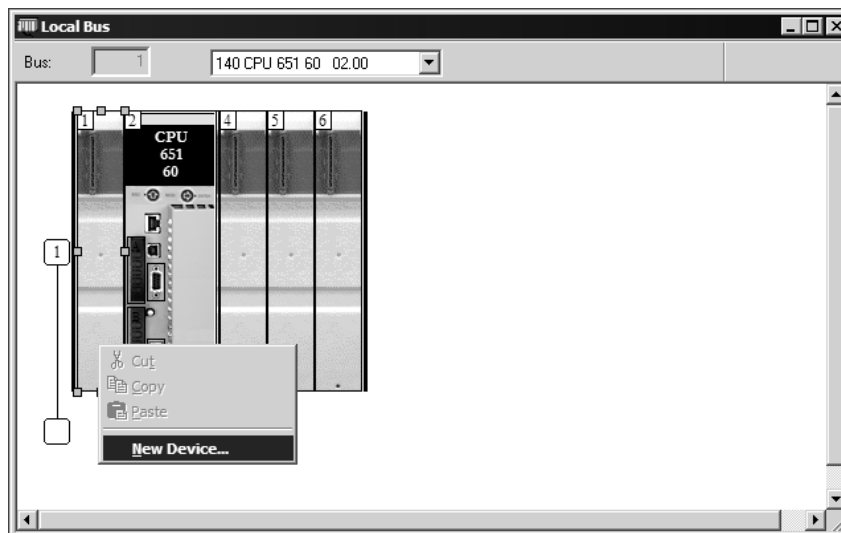

- Expand the Supply folder, and then select your power supply from the list. Click OK to continue.

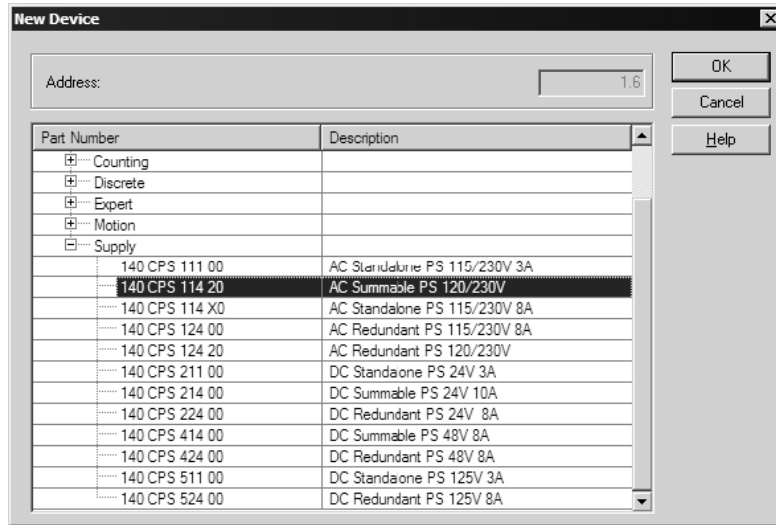

- Repeat these steps to add any additional devices to your Quantum Rack.

4.2 Add the PTQ Module to the Project

- Expand the Communication tree, and select GEN NOM. This module type provides extended communication capabilities for the Quantum system, and allows communication between the PLC and the PTQ module without requiring additional programming.

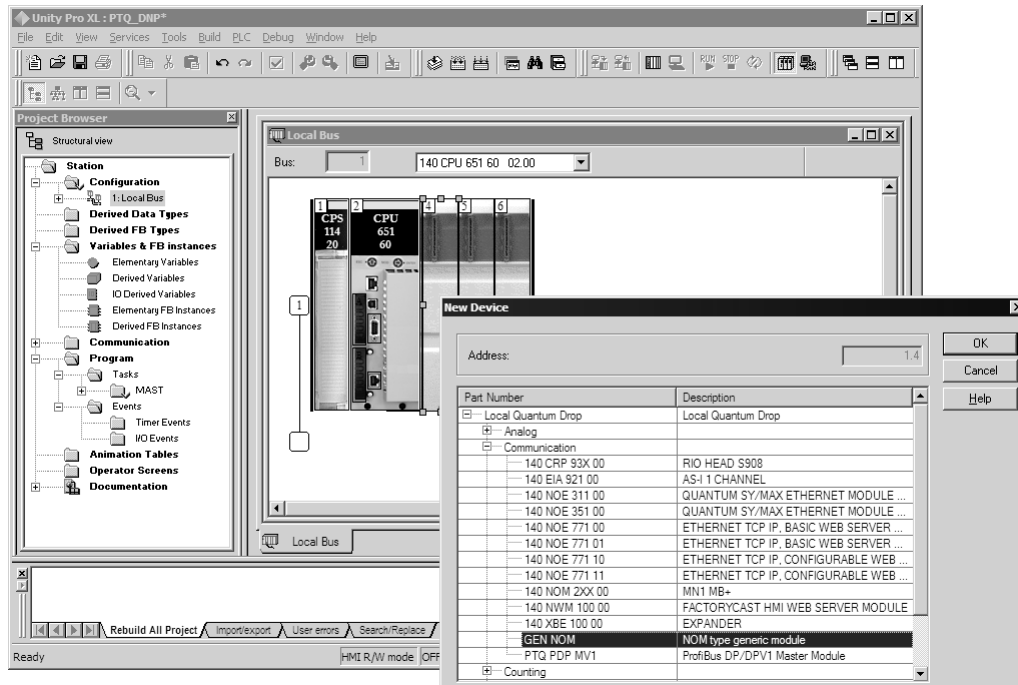

- Next, enter the module personality value. The correct value for ProTalk modules is 1060 decimal (0424 hex).

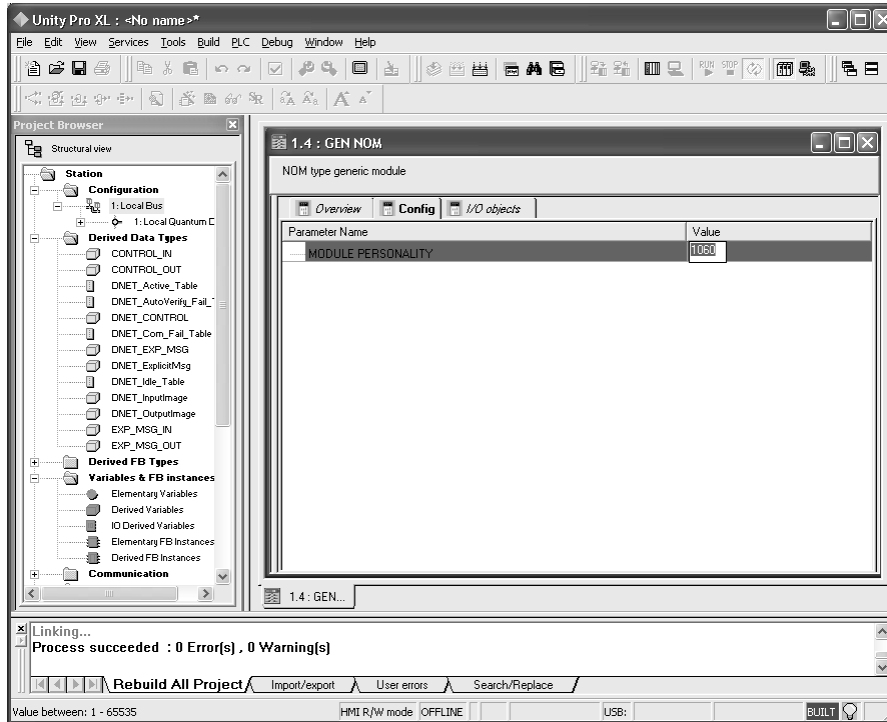

- Before you can save the project in UnityProXL, you must validate the modifications. Open the Edit menu, and then choose Validate. If no errors are reported, you can save the project.
- Save the project.

4.3 Build the Project

Whenever you update the configuration of your PTQ module or the processor, you must import the changed configuration from the module, and then build (compile) the project before downloading it to the processor.

Note: The following steps show you how to build the project in Unity Pro XL. This is not intended to provide detailed information on using Unity Pro XL, or debugging your programs. Refer to the documentation for your processor and for Unity Pro XL for specialized information.

To build (compile) the project:

- 1 Review the elements of the project in the Project Browser.
- 2 When you are satisfied that you are ready to download the project, open the Build menu, and then choose Rebuild all Project. This action builds (compiles) the project into a form that the processor can use to execute the instructions in the project file. This task may take several minutes, depending on the complexity of the project and the resources available on your PC.
- 3 As the project is built, Unity Pro XL reports its process in a Progress dialog box, with details appearing in a pane at the bottom of the window. The following illustration shows the build process under way.

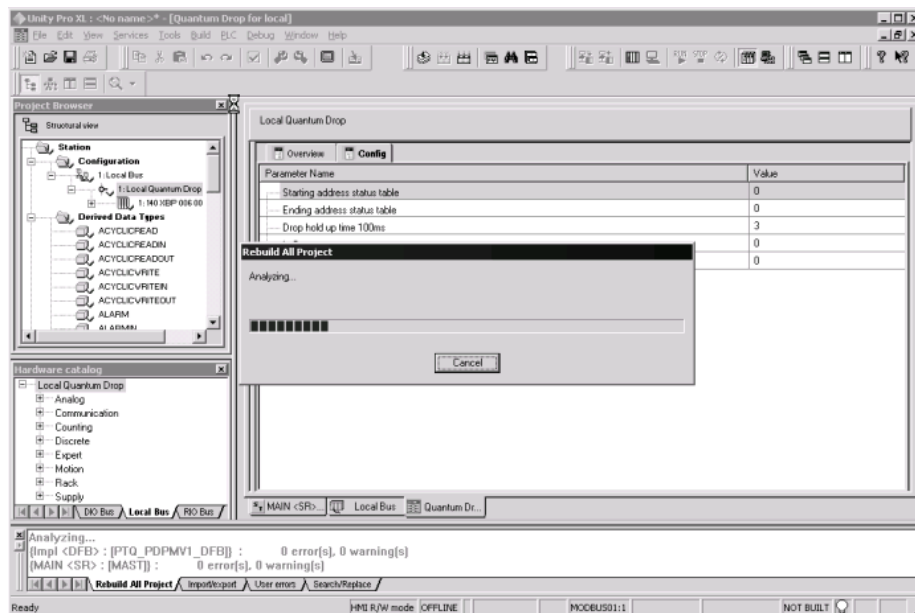

After the build process is completed successfully, the next step is to download the compiled project to the processor.

4.4 Connect Your PC to the Processor

The next step is to connect to the processor so that you can download the project file. The processor uses this project file to communicate over the backplane to modules identified in the project file.

Note: If you have never connected from the PC to your processor before, you must verify that the necessary port drivers are installed and available to UnityPro XL.

To verify address and driver settings in UnityPro XL:

- 1 Open the PLC menu, and choose Standard Mode. This action turns off the PLC Simulator, and allows you to communicate directly with the Quantum or Unity hardware.

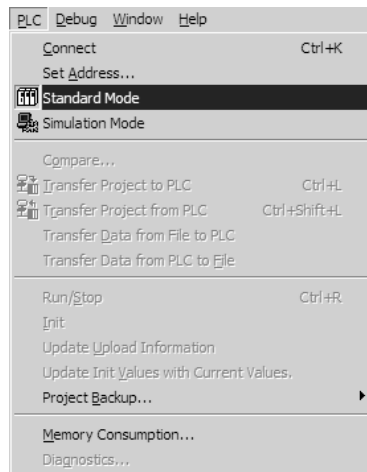

- 2 Open the PLC menu, and choose Set address... This action opens the Set address dialog box. Open the Media dropdown list and choose the connection type to use (TCPIP or USB).

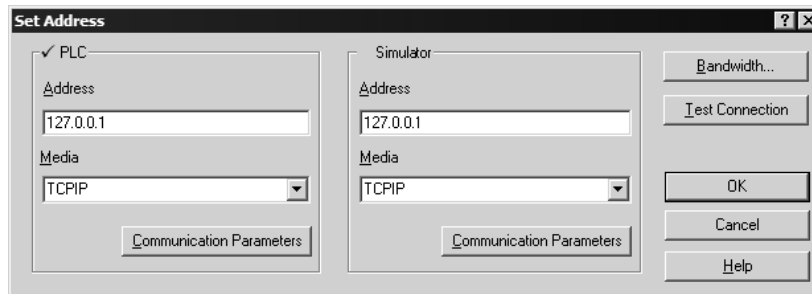

- If the Media dropdown list does not contain the connection method you wish to use, click the Communication Parameters button in the PLC area of the dialog box. This action opens the PLC Communication Parameters dialog box.

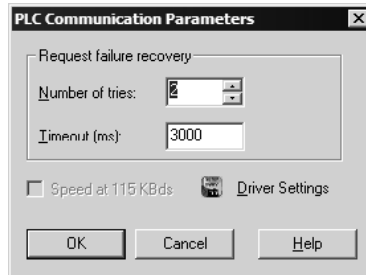

- Click the Driver Settings button to open the SCHNEIDER Drivers management Properties dialog box.

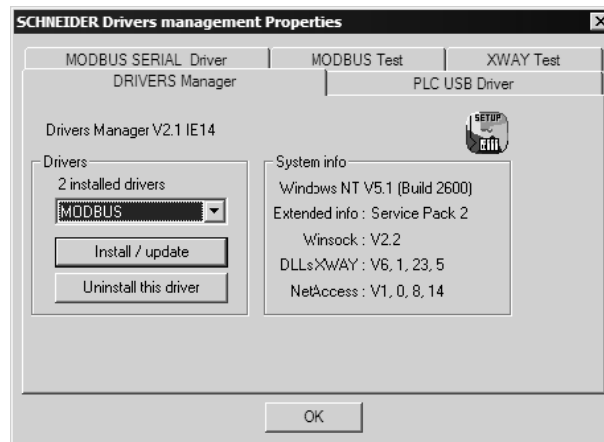

- Click the Install/update button to specify the location of the Setup.exe file containing the drivers to use. You will need your UnityPro XL installation disks for this step.



- Click the Browse button to locate the Setup.exe file to execute, and then execute the setup program. After the installation, restart your PC if you are prompted to do so. Refer to your Schneider Electric documentation for more information on installing drivers for UnityPro XL.

4.4.1 Connecting to the Processor with TCP/IP

The next step is to download (copy) the project file to the processor. The following steps demonstrate how to use an Ethernet cable connected from the Processor to your PC through an Ethernet hub or switch. Other connection methods may also be available, depending on the hardware configuration of your processor, and the communication drivers installed in UnityPro XL.

- 1 If you have not already done so, connect your PC and the processor to an Ethernet hub.
- 2 Open the PLC menu, and then choose Set address.
 - Important: Notice that the Set address dialog box is divided into two areas. Enter the address and media type in the PLC area of the dialog box, not the Simulator area.
- 3 Enter the IP address in the address field. In the Media dropdown list, choose TCP/IP.
- 4 Click the Test Connection button to verify that your settings are correct.

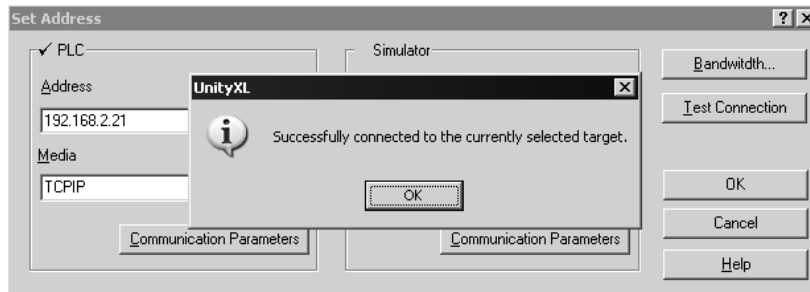

4.5 Download the Project to the Processor

- 1 Open the PLC menu and then choose Connect. This action opens a connection between the Unity Pro XL software and the processor, using the address and media type settings you configured in the previous step.
- 2 On the PLC menu, choose Transfer Project to PLC. This action opens the Transfer Project to PLC dialog box. If you would like the PLC to go to "Run" mode immediately after the transfer is complete, select (check) the PLC Run after Transfer check box.

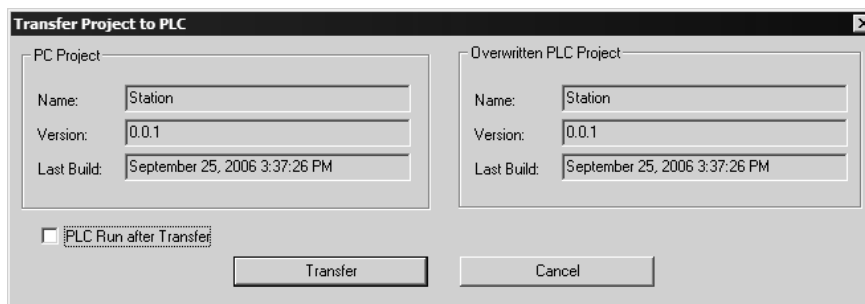

- 3 Click the Transfer button to download the project to the processor. As the project is transferred, Unity Pro XL reports its process in a Progress dialog box, with details appearing in a pane at the bottom of the window.

When the transfer is complete, place the processor in Run mode.

5 Setting Up the ProTalk Module

In This Chapter

- ❖ Install the ProTalk Module in the Quantum Rack 43
- ❖ Connect the PC to the ProTalk Configuration/Debug Port 44
- ❖ Verify Communication Between the Processor and the Module..... 46

After you complete the following procedures, the ProTalk module will actively be transferring data bi-directionally with the processor.

5.1 Install the ProTalk Module in the Quantum Rack

5.1.1 Install the ProTalk Module in the Quantum Rack

- 1 Place the Module in the Quantum Rack. The ProTalk module must be placed in the same rack as the processor.
- 2 Tilt the module at a 45° angle and align the pegs at the top of the module with slots on the backplane.

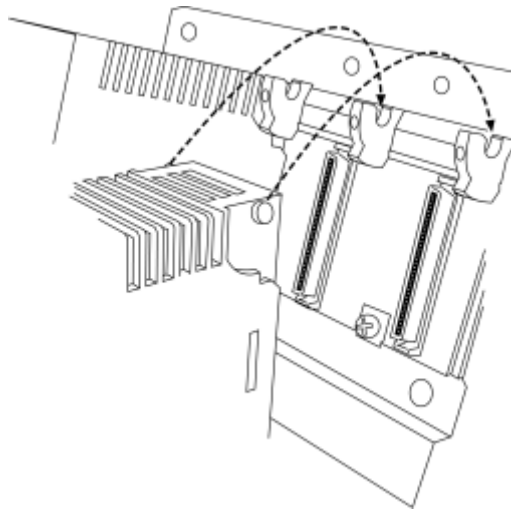

- 3 Push the module into place until it seats firmly in the backplane.

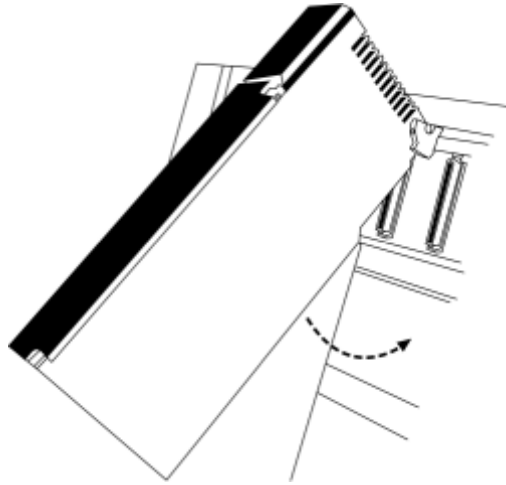

Caution: The PTQ module is hot-swappable, meaning that you can install and remove it while the rack is powered up. You should not assume that this is the case for all types of modules unless the user manual for the product explicitly states that the module is hot-swappable. Failure to observe this precaution could result in damage to the module and any equipment connected to it.

5.2 Connect the PC to the ProTalk Configuration/Debug Port

Make sure you have exited the Quantum programming software before performing these steps. This action will avoid serial port conflict.

- 1 Using the supplied Null Modem cable, connect your PC to the Configuration/Debug port on the ProTalk module as shown

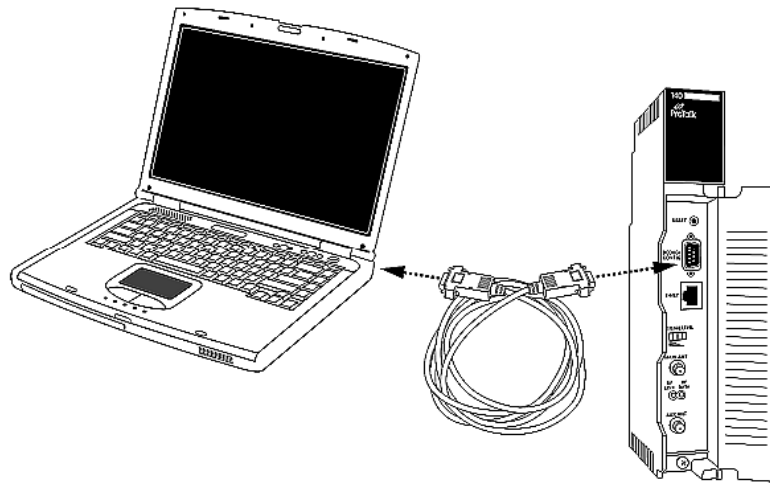

- 2 Click the Windows Start button, then choose Programs / Accessories / Communications / HyperTerminal.

- 3 In the HyperTerminal window, enter a connection name, for example **Test**, and then click OK. This action opens the Connect To dialog box.



- 4 In the Connect Using field, ensure that the com port matches the port on your PC to which you connected the Null Modem cable, and then click OK. This action opens the COMx Properties dialog box.

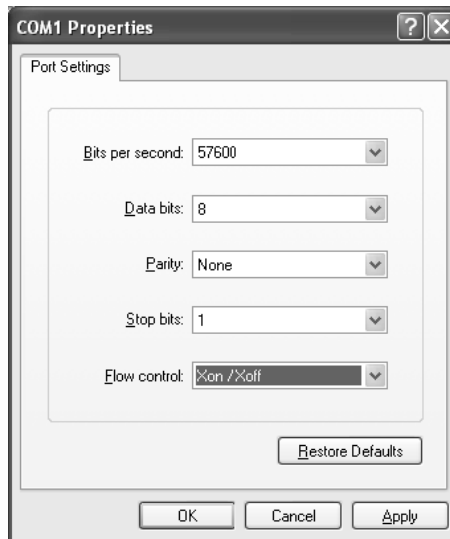

- 5 Verify that the settings match those shown in the example above, and then click OK. If your port settings are configured correctly, you will return to the HyperTerminal window.
- 6 In the HyperTerminal window, press [?]. This action opens the module's Configuration/Debug menu.

5.3 Verify Communication Between the Processor and the Module

This procedure will verify that the clock values we entered in the processor's data memory (page 20) can be read into the ProTalk module.

- 1 From the *Configuration/Debug Menu*, type **[D]**, then press **[?]**. This action opens the *Database View Menu*.

```

DATABASE VIEW MENU
?=Display Menu
0-3=Pages 0 to 3000
S=Show Again
-=Back 5 Pages
P=Previous Page
+=Skip 5 Pages
N=Next Page
D=Decimal Display
H=Hexadecimal Display
F=Float Display
A=ASCII Display
M=Main Menu
    
```

- 2 Type **[0]** (zero). This displays values present in the ProTalk database for 0 to 99.

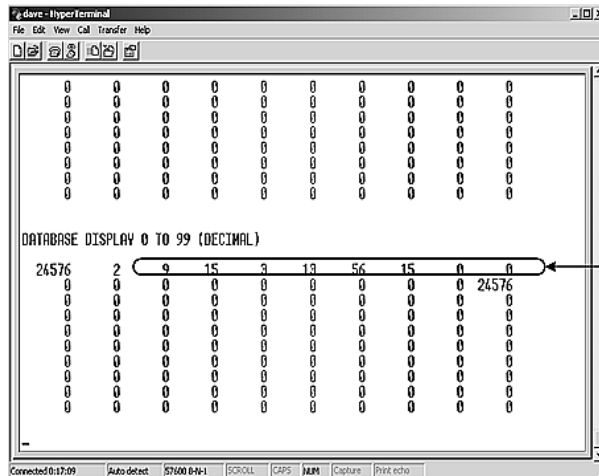

Shows date and time values set on the PLC

Value	Description
9	Month (September)
15	Day of the Month
3	Year (2003)
13	Hour (13:00 or 1:00 P.M.)
56	Minutes
15	Seconds

In this example, the register values read from the PLC indicate that the date and time returned is September, 15, 2003, 1:56:15 p.m.

- 3 Type [0] again. The values should be different than those shown in the previous view. For example, the minute and second values should be incrementing just as the values on the PLC are also incrementing.

At this point, you have successfully:

- Installed and set up the ProTalk module
- Verified Data Read access between the processor and the ProTalk module

You are now ready to proceed with implementation of your application.

Because the task of configuring the PWP Wireless network can be complicated, ProSoft Technology has provided a configuration tool called ProSoft Configuration Builder (PCB) that will help you with the following tasks:

- Creating a configuration project
- Setting module parameters
- Configuring the wireless network
- Copying the project to the module.

The following topics of this chapter explain each task step-by-step.

Tip: A sample configuration file (PPF file) is provided on the ProSoft Solutions CD-ROM that contains the configuration allowing the PTQ-WA-PWP module and a ProLinx 6104-WA-PDPM module to communicate wirelessly.

5.4 ProSoft Configuration Builder

ProSoft Configuration Builder (PCB) provides a quick and easy way to manage module configuration files customized to meet your application needs. PCB is not only a powerful solution for new configuration files, but also allows you to import information from previously installed (known working) configurations to new projects.

5.4.1 Set Up the Project

To begin, start ProSoft Configuration Builder. If you have used other Windows configuration tools before, you will find the screen layout familiar. ProSoft Configuration Builder's window consists of a tree view on the left, an information pane and a configuration pane on the right side of the window. When you first start ProSoft Configuration Builder, the tree view consists of folders for Default Project and Default Location, with a Default Module in the Default Location folder. The following illustration shows the ProSoft Configuration Builder window with a new project.

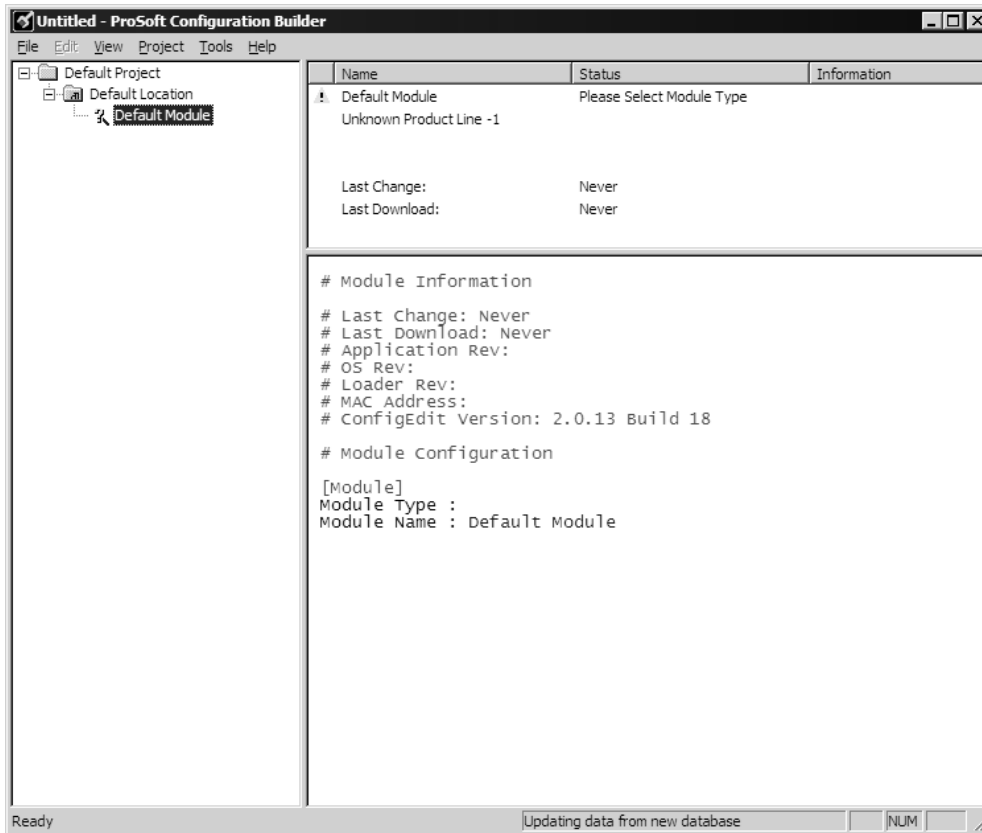

Your first task is to add the PTQ-WA-PWP module to the project.

- 1 Use the mouse to select "Default Module" in the tree view, and then click the right mouse button to open a shortcut menu.

- 2 On the shortcut menu, choose "Choose Module Type". This action opens the Choose Module Type dialog box.



- 3 In the Product Line Filter area of the dialog box, select PTQ. In the Select Module Type dropdown list, select PTQ-WA-PWP, and then click OK to save your settings and return to the ProSoft Configuration Builder window.

The next task is to set the module parameters.

Adding a Project

To add a project to an existing project file:

- 1 Select the Default Project icon.
- 2 Choose Project from the Project menu, then choose Add Project. A new project folder appears.

Adding a Module

To add a module to your project:

- 1 Double-click the Default Module icon to open the Choose Module Type dialog box.

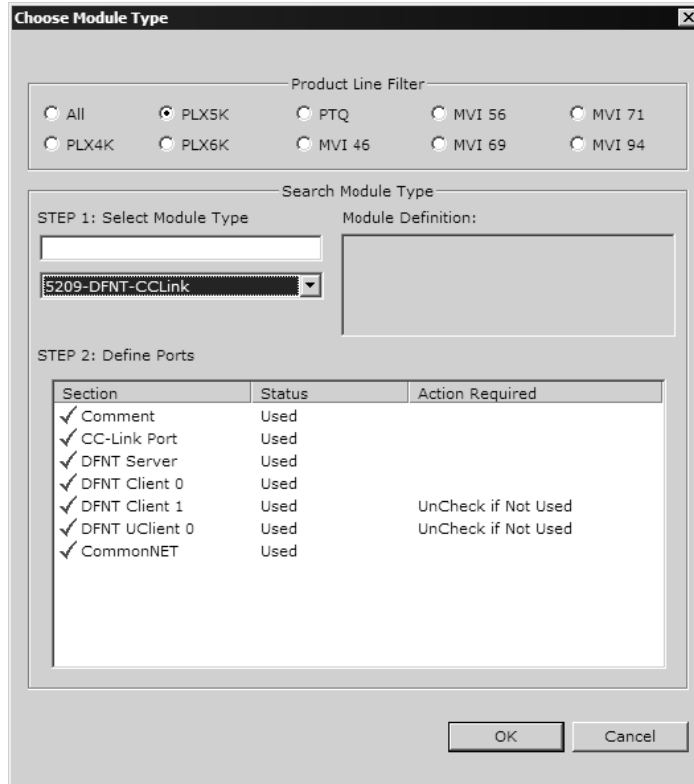

- 2 On the Choose Module Type dialog box, select the module type.
Or
 - 1 Open the Project menu and choose Location.
 - 2 On the Location menu, choose Add Module.

To add a module to a different location:

- 1 Right-click the Location folder and choose Add Module. A new module icon appears.
Or
 - 1 Select the Location icon.
 - 2 From the Project menu, select Location, then select Add Module.

5.4.2 Set Module Parameters

Notice that the contents of the information pane and the configuration pane changed when you added the PTQ-WA-PWP module to the project.





At this time, you may wish to rename the "Default Project" and "Default Location" folders in the tree view.

To rename an object:

- 1 Select the object, and then click the right mouse button to open a shortcut menu. From the shortcut menu, choose Rename.
- 2 Type the name to assign to the object.
- 3 Click away from the object to save the new name.



Module Entries

To configure module parameters

- 1 Click on the  icon to expand module information.
- 2 Double-click the  icon to open the Edit dialog box.
- 3 To edit a parameter, select the parameter in the left pane and make your changes in the right pane.
- 4 Click OK to save your changes.

Comment Entries

To add comments to your configuration file:

- 1 Click the plus sign to the left of the  Comment icon to expand the Module Comments.
- 2 Double-click the  Module Comment icon. The Edit - Module Comment dialog appears.

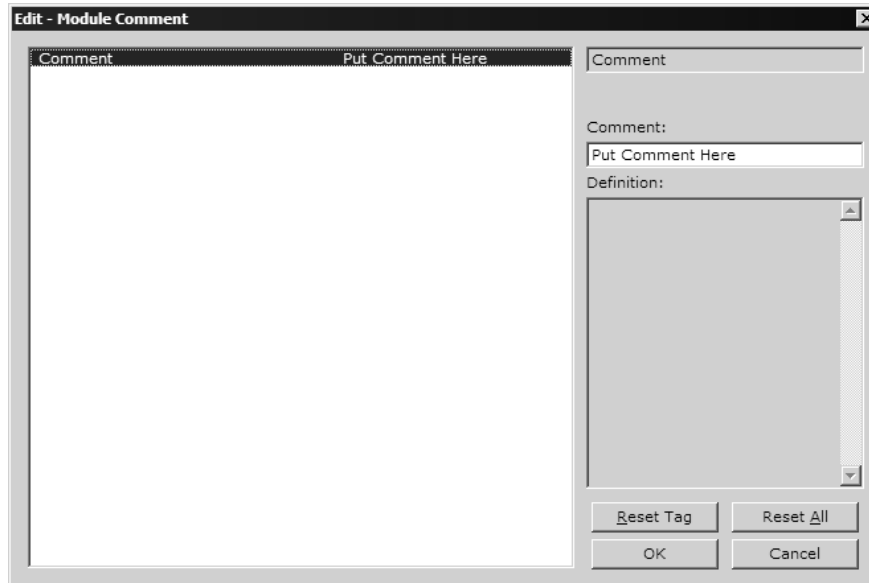

- 3 Enter your comment and click OK to save your changes.

Adding a Location

To add a location to an existing project file:

- 1 Right-click the Project icon and select Add Location. A new Location icon appears.
or
Select the Project icon.
- 2 Choose Project from the Project menu, then choose Add Location. A new Location icon appears.
or
If the Default Location has not been named (is not already an existing project), right-click the folder and choose Rename.
- 3 Type in the Location name.

Printing a Configuration File

To print a configuration file:

- 1 Select the Module icon, and then click the right mouse button to open a shortcut menu.

- 2 On the shortcut menu, choose View Configuration. This action opens the View Configuration window.
- 3 On the View Configuration window, open the File menu, and choose Print. This action opens the Print dialog box.
- 4 On the Print dialog box, choose the printer to use from the dropdown list, select printing options, and then click OK.

5.5 [Backplane Configuration]

This section designates database addresses for input and output on the module and on the processor, and identifies the method of failure for the communications for the module if the processor is not in run mode.

The following example shows a sample [Backplane Configuration] section:

```
[Backplane Configuration]
Read Register Start   :    0 # DB start location in module for data moved from
                        # module to processor.
Read Register Count   : 1000 # Number of registers to move from module to
                        # processor.
Write Register Start  : 1000 # DB start location in module for data moved from
                        # processor to module.
Write Register Count  : 1000 # Number of registers to move from processor to
                        # module
Failure Flag Count    :    0 #
```

5.5.1 Read Register Start

Range 0 to 3999

This parameter specifies the starting register in the module where data will be transferred from the module to the processor. Valid range for this parameter is 0 to 3999.

5.5.2 Read Register Count

Range 0 to 3999

This parameter specifies the number of registers to be transferred from the module to the processor. Valid entry for this parameter is 0 to 3999.

5.5.3 Write Register Start

0 to 3999

This parameter specifies the starting register in the module where the data will be transferred from the processor to the module.

5.5.4 Write Register Count

Range 0 to 3999

This parameter specifies the number of registers to transfer from the processor to the module. Valid entry for this parameter is 0 to 3999.

5.5.5 Failure Flag Count

0 through 65535

This parameter specifies the number of successive transfer errors that must occur before the communication ports are shut down. If the parameter is set to 0, the communication ports will continue to operate under all conditions. If the value is set larger than 0 (1 to 65535), communications will cease if the specified number of failures occur.

5.6 [Radio Configuration]

The Radio Configuration section contains basic configuration parameters for the radio. The following settings configure the radio.

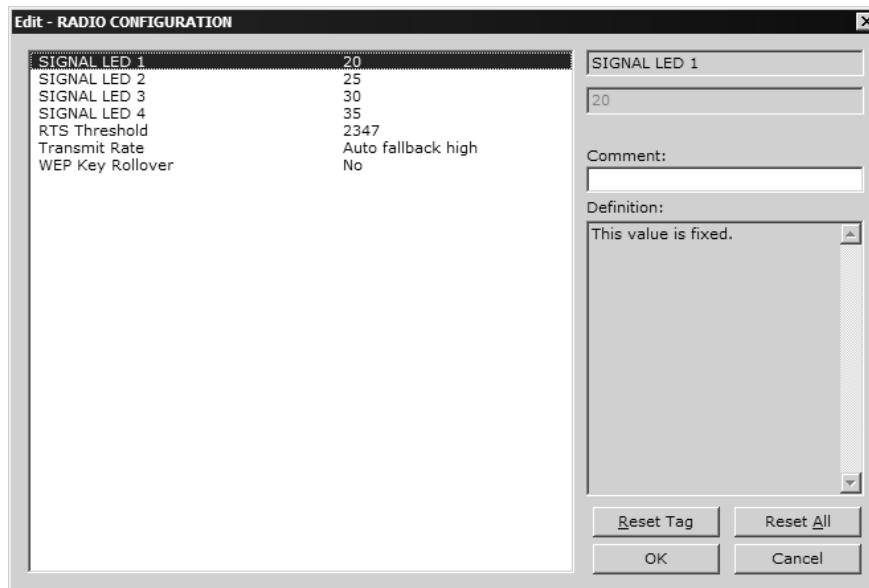

5.6.1 Signal LED 1, 2, 3, 4

SIGNAL LED 1: 20

SIGNAL LED 2: 25

SIGNAL LED 3: 30

SIGNAL LED 4: 35

The Signal LEDs on the front of the module indicate the current quality (signal strength minus noise) of the radio signal. The parameter for each LED determines the signal strength level at which the LED will illuminate.

After the module powers up, all signal LEDs will be off. When the module establishes a connection to another module, the signal LEDs will display the strength of the radio signal.

If the radio communication is dropped when in ad-hoc mode (for example, if the other radio is turned off), the signal strength LEDs will flash periodically at a rate of approximately 10 seconds on and one second off.

5.6.2 *Transmit Rate*

This parameter defines the data rate(s) for transmission of directed messages. Possible values are outlined in the following table.

Value	Definition
1	Fixed 1 Mbit (1)
2	Fixed 2 Mbit (2)
3	Auto fallback high (11, 5.5, 2, 1)
4	Fixed medium rate (5.5)
5	Fixed high rate (11)
6	Auto fallback standard (2, 1)
7	Auto fallback medium (5.5, 2, 1)

Important: For Multicast mode, use transmit rates of 1 or 2 Mbps for best results.

5.6.3 *WEP Key Rollover*

Yes or No

WEP (Wireless Encryption Protocol) is an encryption method that allows devices on a wireless network to transmit data securely.

This parameter interacts with the WATTCP parameter "Enable Encryption", and the values for WEP Keys 1 through 4. When the WEP Key Rollover parameter is enabled, the module will randomly change the WEP key.

5.7 [Radio SNTP Client]

The [Radio SNTP Client] section specifies the parameters for the Simple Network Time Protocol (SNTP) client provided with the protocol driver. This client is required in order to keep the driver's internal clock set correctly. This version of the driver supports the unicast implementation of the SNTP Revision 3 and stratum between 1 and 14.

The module can be configured to periodically synchronize its clock with a remote SNTP server. Approximately every 6 minutes the module sends 10 consecutive requests to the remote SNTP client (at approximately 6 second intervals). You can check these requests and responses by looking at the SNTP Client Configuration Menu (press the N key at the Configuration/Debug Main Menu). If the module receives a valid response from the SNTP server, the computations value will be also be incremented. After 10 consecutive successful requests and responses, the module will synchronize its internal clock (an average is performed based on all 10 responses for better accuracy). The Time Set Cnt value is incremented every time the clock is synchronized.

After the synchronization is performed, the time valid register is set to Yes. If the module cannot connect to the remote SNTP server after 3 consecutive attempts, the time valid register is set to No. You can also configure the GMT settings to use, and the database address where the date and time information can be copied.

The following parameters set up the SNTP client:

```
[RADIO SNTP CLIENT]
NTP SERVER IP ADDRESS      : 0.0.0.0 # IP address for NIST, Boulder, Colorado
TIME_ZONE                  :      8 # Number of hours from GMT (-11 to +11)
USE DAYLIGHT SAVINGS TIME :     No # Yes or No
DATABASE REGISTER         :    3000 # database word location where to store
                               # time (-1=ignore).
```

The database register parameter defines a database register where the SNTP time and date values are copied. It occupies 4 words as follows:

Word Offset	Description
0 and 1	Date and time in Unix format (long integer)
2 and 3	Microseconds (long integer)

5.7.1 NTP Server IP Address

Enter in dotted notation

This parameter sets the IP address of the NTP server to contact for time acquisition. Select an NTP server with the greatest accuracy that is available all the time from your network. Set this IP address to 0.0.0.0 to disable SNTP server requests.

5.7.2 Time Zone

-11 to 11

This parameter sets the time zone offset from UTC. Positive values are for time zones west of UTC, and negative values are for time zones east of UTC. Set this value to 0 to use UTC in the module.

5.7.3 Use Daylight Savings Time

Yes or No

This parameter specifies if daylight savings time will be used in the time computation.

5.7.4 Database Register

-1 or 0 to 3992 as an even value

This parameter specifies if the NTP time computed by the driver is to be placed into the module's database. If a value of -1 is specified, the time will not be placed into the database. If the value is between 0 and 3992, the time will be placed in the database. The first 4 bytes represent the seconds since 1/1/1970, and the second 4 bytes represent the number of microseconds. An even value should be used for the register value in order for the data to be stored correctly.

5.8 [RADIO PWP Exchanges]

In order to interface the module with PWP devices, you must construct an exchange list. The exchanges specify messages that will be produced or consumed at a user-defined frequency using the module's internal database. Messages can be broadcast to all nodes on the network, sent to a multicast group on the network or associated with a single node on the network. Up to 100 exchanges can be defined for the driver. Up to 680 word registers can be produced or consumed in a single exchange.

The [RADIO PWP Exchanges] section defines the messages that will be produced and consumed by the driver. The UDP protocol on the IP network is used to transport these over Ethernet between all the PWP devices.

For the exchanges to operate correctly, the other PWP devices must be configured and correctly set up. The primary reason for user problems with the module is failure to provide devices that are correctly configured. Before trying to connect the module to the network, the remote device must be able to communicate with ProSoft Configuration Builder. You must understand and document all parameters.

5.8.1 Exch Type

Producer: exchange will be producing data to other stations

Consumer: exchange will be consuming data from another station

The Exchange Type field defines the type of exchange used in the exchange as either producer or consumer. Producer exchanges (P) are generated by the driver using the module's database. Consumer exchanges (C) are those received from other WA-PWP devices with the data in the message being placed in the module's database.

5.8.2 Cast Type

When the Exchange Type is **Producer**, the cast type field determines if the exchange is a unicast ('U' = point-to-point) exchange, multicast ('M'=multicast group) or a broadcast ('B' = all nodes) exchange.

- Producer Unicast - produce message to another station
- Producer Multicast - produce message to a group of stations. In order to use this option you need to configure the same Multicast IP address used in the exchange also at the [RADIO PWP MULTICAST GROUP LIST] section.

Important: For Multicast mode, use transmit rates (page 55) of 1 or 2 for best results.

- Producer Broadcast - produce message to all stations (set exchange IP address to 255.255.255.255)

When the Exchange Type is **Consumer**, the cast type field determines how the local database area associated to this exchange will be updated in case an RF Error (timeout) occurs.

- Consumer No DB Change on RF Error
- Consumer Set DB to -1 On RF Error
- Consumer Set DB to 0 On RF Error
- Consumer Set DB to 1 On RF Error

5.8.3 DB Reg

The DB Register field defines the starting database register in the module where data sourced (produced data) or placed (consumed data) is determined by the value entered in the DB Reg column. This parameter can have a value of 0 to 3999. The validity of the entry is dependent on the number of registers (Reg Count) to be produced or consumed. The sum of the two values cannot exceed 4000, as this would be outside the range of the module's database.

5.8.4 Reg Count

Number of database registers to transfer/accept in message.

5.8.5 Swap Code

0, 1, 2 or 3

The Swap Code field sets byte and word swapping of data produced or consumed. Swapping of words and/or bytes in the message may be required for different protocol and operating systems as their representation of multi-byte values may not be the same as that of the WA-PWP protocol.

Swap Code	Description
0	None - No Change is made in the byte ordering (1234 = 1234)
1	Words - The words are swapped (1234=3412)
2	Words & Bytes - The words are swapped then the bytes in each word are swapped (1234=4321)
3	Bytes - The bytes in each word are swapped (1234=2143)

5.8.6 P/C Time

The P/C Time field defines the number of milliseconds between productions of the exchange data and for consumed exchanges. This value defines the number of milliseconds to wait for a produced exchanged before a timeout condition is present.

- For a producer exchange it defines the number of milliseconds between consecutive producer exchanges.
- For a consumer exchange it defines the number of milliseconds to wait for a produced message before a timeout error is set. It is suggested to use a value at least four times greater than the value used in the producer exchange.

For consumed messages, set this value to approximately 4 times the produced time of the exchange on the other device. This will prevent the exchange from constantly timing out on a busy network. If this parameter is set to zero, the message will not be produced.

A zero value for a consumed message indicates that the exchange will never timeout. The zero value can be used for exchanges that will interface with the command service port (7937) to handle data read and write requests from another device.

5.8.7 IP Address

The IP Address field should be set to the IP address of destination device (produced data) or source device (consumed data).

Producer Exchange IP address: If the cast type is set to 'U' for a produced exchange, the address should be set to IP address of the specific node to receive (consume) the data. If the cast type is set to 'B' for produced data, set the IP to either a network (255.255.255.255) or subnet (192.168.0.255) broadcast address. If the cast type is set to 'M' for produced data, set the IP address to a valid multicast address.

Multicast Address Assignments

Important: Use Multicast whenever the module produces data to at least two other modules. Using Unicast for these applications can cause data transmission delay when at least one of the consumer modules is powered down.

Multicast group addresses 224.0.7.1 to 224.0.7.32 are reserved. The module does not place this limit for messages but the user should consider using the reserved group addresses. The following table shows the relationship between multicast group parameters and IP addresses. Refer to Underlying Protocol Requirements and Constraints for more detailed information on IP and UDP addresses.

Parameter	IP Address
Group 1	224.0.7.1
Group 2	224.0.7.2
...	...
Group 32	224.0.7.32

Important: For Multicast mode, use transmit rates (page 55) of 1 or 2 for best results.

Consumer Exchange IP address: For consumed messages both Broadcast and Multicast type messages should be set to the IP address of the producer generating the specific exchange. The combination of the IP address and the exchange ID uniquely identify the exchange to the system.

5.8.8 Exch ID

1 to 16383

The Exch ID field defines the Exchange ID for this message, and must be unique for each node. For produced exchanges, the module IP address and the entered exchange ID uniquely define the exchange to the network. Defined consumer exchanges use the IP address in the message along with this exchange ID to determine which exchange to associate with the message. The parameters defined in the exchange then determine how much data is present in the message and where to place it into the module's internal database.

5.8.9 CS Major, CS Minor

This is an optional functionality that can be used to prevent unexpected results when changes are performed to existing producer and consumer exchanges.

The Configuration Signature consists of two one-byte integer value (CS Major and CS Minor). The CS Major must be equal for both Producer and Consumer exchanges. The CS Minor reflects backward compatible modifications made to an exchange (for example: adding registers to the producer exchange count). Truncating data within an exchange is not backward compatible and requires a change in the major number.

The purpose of the Configuration Signature (CS) is to guarantee that the produced exchange will contain data in a format expected by a consumer module. Therefore it prevents the consumer module to process received data if it is not compatible because of later modifications.

Whenever a consumer module receives an exchange message, it will look for a configured consumer exchange that contains the same Exchange ID. If it finds a matching consumer exchange it will compare the Configuration Signature for validation.

If the exchange is not validated then the data will not be consumed.

Because this functionality is optional, the modules will exchange data even if the Configuration Signature validation is disabled. To disable this functionality, configure all exchanges with both CS Major and CS Minor values equal to zero.

The following rules are used by the consumer module to validate an exchange based on its Configuration Signature:

Rules for CS Validation

An exchange will be considered valid if at least one of the following conditions is true:

- Producer CS Major and CS Minor are both equal to 0
- Consumer CS Major and CS Minor are both equal to 0
- Producer CS Major is equal than Consumer CS Major AND Producer CS Minor is greater or equal than Consumer CS Minor

The following table contains some examples that will help you to understand the consumer criteria to validate received exchanges based on the Configuration Signature:

Producer CS Major	Producer CS Minor	Consumer CS Major	Consumer CS Minor	Will Data be Consumed?	Comment
0	0	0	0	Yes	Same CS value of 0.0 (Major.Minor) validates the exchange
0	0	1	2	Yes	Producer CS value of 0.0 (Major.Minor) validates the exchange
1	2	0	0	Yes	Consumer CS value of 0.0 (Major.Minor) validates the exchange
1	2	1	2	Yes	Same CS value (1.2) validates the exchange
2	2	1	2	No	CS Major mismatch - exchange is not validated

Producer CS Major	Producer CS Minor	Consumer CS Major	Consumer CS Minor	Will Data be Consumed?	Comment
1	2	2	2	No	CS Major mismatch - exchange is not validated
1	2	1	1	Yes	Same CS Major and Consumer CS Minor is less than Producer CS Minor - exchange is validated
1	2	1	3	No	Same CS Major but Consumer CS Minor is greater than Producer CS Minor - exchange is not validated

5.8.10 Radio PWP Exchange Command List Example

The following is an example section from the [PWP Exchanges] section:

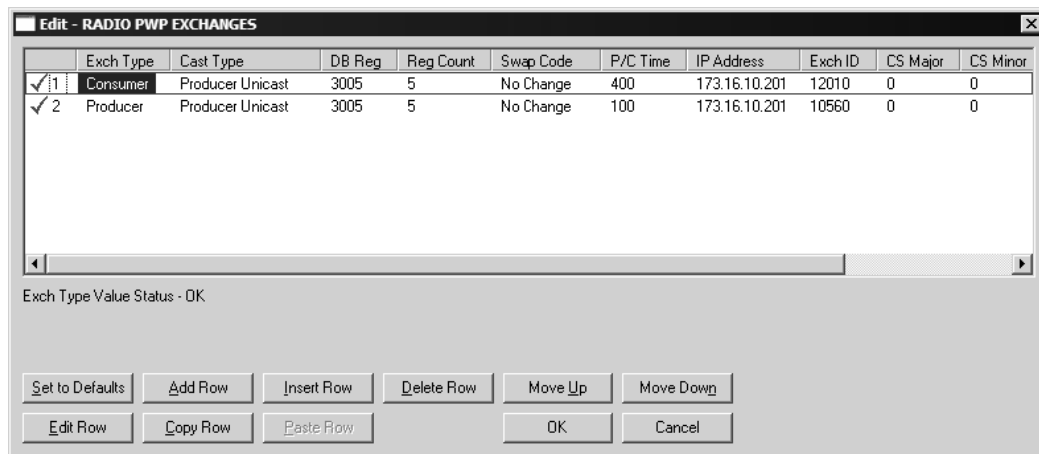

5.9 [Radio PWP Multicast Group List]

This section contains the list of multicast group addresses the PWP server should process (consumer messages for this server produced on other units). This list may contain up to 16 IP addresses. The reserved group addresses for the PWP protocol are 224.0.7.1 to 224.0.7.32. The module will support other group addresses than this data set.

Important: Use Multicast whenever the module produces data to at least two other modules. Using Unicast for these applications can cause data transmission delay when at least one of the consumer modules is powered down.

5.10 Radio Ethernet Configuration

The Radio Ethernet Configuration is used to configure ethernet and wireless communication information.

```
# EtherNet Configuration
```

```
Radio_IP           : 172.16.10.240
Radio_Subnet_Mask  : 255.255.255.0
Radio_Default_Gateway : 172.16.10.1
```

```
Network_Name_(SSID) : PWP-COMS
Station_Name       : PTQ-WA-PWP
Channel            : 6
Enable_Encryption  : N
WEP_Key_1         : 0x382271776f782a6d47286a6b33
WEP_Key_2         : 0x6a387e23334e6d3f3c66243f72
WEP_Key_3         : 0x777b563f39204c565b2a504e65
WEP_Key_4         : 0x6a4168674f5a6d744f32346e6b
Transmit_WEP_Key   : 1
```

5.10.1 Radio_IP

Default: 192.168.0.100

The IP address of the module to be used in wireless communication.

5.10.2 Radio_Subnet_Mask

Default: 255.255.255.0

The subnet mask to be used in wireless communication.

5.10.3 Radio_Default_Gateway

Default: 172.16.10.1

The default gateway to be used in wireless communication.

5.10.4 Network_Name_(SSID)

Valid Values: any character in the range of "A to Z", "a to z" and "0 to 9" where:

- The value "ANY" enables your station to connect to any IEEE 802.11 compliant network.
- A "user-defined name" allows your station to connect to a specific network only. This value should match the value as set for the Access Point in your wireless network.

The SSID used when connecting to a wireless network used by an Access Point or Ad hoc station. Value can be alphanumeric string with a maximum of 32 ASCII characters that identifies the network to which you would like to connect your wireless station.

You should configure all modules that will be exchanging data to use the same SSID.

5.10.5 Create_IBSS

The following options are applicable during the module's power-up initialization in its attempt to connect to available devices.

Yes

- a** Connect Infrastructure (ESS) when Access Point IS available.
- b** Connect Ad-hoc (IBSS) when Access Point NOT available.

No

- a** Connect Infrastructure (ESS) when Access Point IS available.
- b** Will NOT connect Ad-hoc (IBSS) when Access Point NOT available.

5.10.6 Station_Name

An alphanumeric string with a maximum of 32 ASCII characters that will identify your station on the wireless network.

Valid Values: any character in the range of "A to Z", "a to z" and "0 to 9".

5.10.7 Channel

0 to 14 (Default 10)

Channel this module will use on the wireless network. Used for creating Ad hoc link. Channels 1 to 14 are available. FCC allows for channels 1 to 11, ETSI (Europe) channels 1 to 13, France channels 1 to 9, Japan channels 1 to 14. Contact ProSoft Technology for country approval list.

All modules for the same network should use the same channel number.

5.10.8 Enable_Encryption

Y = Yes. Enable WEP encryption

N = No. Do not enable WEP encryption

(Default = N)

Enables or Disables WEP encryption.

When this parameter is enabled, you can:

- Select up to four key for decrypting data received via the wireless interface.
- Select one Transmit key for encrypting data that will be transmitted via the wireless interface.

If you decide to enable encryption, please note that all stations will be configured with identical WEP key values.

5.10.9 WEP_Key_1 to WEP_Key_4

5-character ASCII key or 10-digit hexadecimal key for 64-bit encryption.

13-character ASCII key or 26-digit hexadecimal key for 128-bit encryption.

Identifies one of the four keys your station device can use to decrypt data received via its wireless interface. 64-bit or 128-bit encryption is selected by the number of characters.

The key value is case-sensitive. Hexadecimal values must be preceded by "0x". All wireless clients and access points should be configured with identical key values.

Note: Use only WEP Key 1 when communicating with an RLX-IH access point/repeater.

5.10.10 *Transmit_WEP_Key*

Selects which WEP key to use for encryption.

Note: If the WEP Key Rollover parameter is enabled, then the module will use a random WEP key out of the four provided, overriding any value specified in this parameter.

6 Verify Radio Communications

In This Chapter

- ❖ Save and Download the Configuration File to the PTQ-WA-PWP 65
- ❖ Save and Download the Configuration File to the 6104-WA-PDPM 67
- ❖ Verify Data Exchange..... 68

This chapter shows how to use the sample configuration file PTQ-WA-PWP_to_6104-WA-PDPM.ppf, on the ProSoft Solutions CD, to communicate wirelessly between two modules:

- PTQ-WA-PWP
- ProLinx 6104-WA-PDPM

This sample configuration is just one example of the many ProSoft Wireless Protocol modules in the inRAX, ProLinx and ProTalk product lines that are capable of communicating wirelessly with each other.

6.1 Save and Download the Configuration File to the PTQ-WA-PWP

With the module securely mounted, connect your PC to the Configuration/Debug port using the RJ45-DB-9 Serial Adapter Cable and the Null Modem Cable included in the package with the PTQ-WA-PWP module.

- 1 Connect the RJ45-DB-9 Serial Adapter Cable to the Null Modem Cable.
- 2 Insert the RJ45 cable connector from the RJ45-DB-9 cable into the Configuration/Debug port of the module.
- 3 Attach the other end to the serial port on your PC.
- 4 In ProSoft Configuration Builder, choose **File / Save As...** and save the .PPF file to a location on your hard drive.

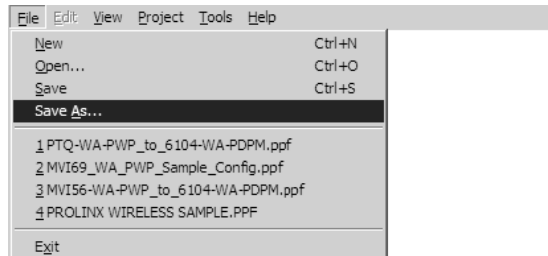

- 5 Right-click on PTQ-WA-PWP and select **Download from PC to Device**.



- 6 Select the appropriate COM port and click the **Download** button.

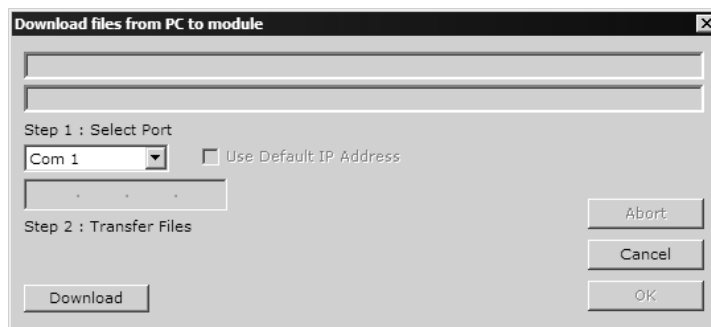

- 7 The download is complete when the OK button becomes active. When the download is completed, click the **OK** button.

6.2 Save and Download the Configuration File to the 6104-WA-PDPM

- 1 Connect your PC to the DEBUG port of the 6104-WA-PDPM module. Apply power to the module if you have not already done so.

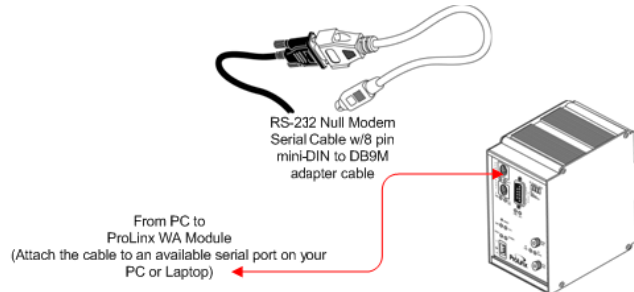

- 2 Right-click on 6104-WA-PDPM and select **Download from PC to Device**.

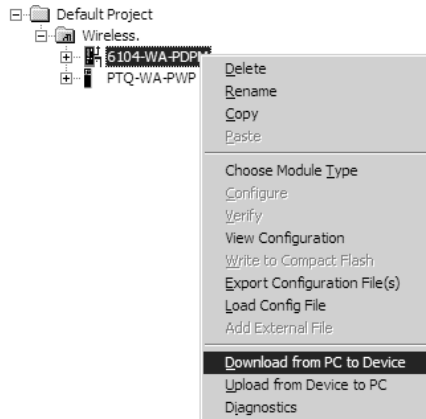

- 3 Select the appropriate COM port and click the **Download** button.

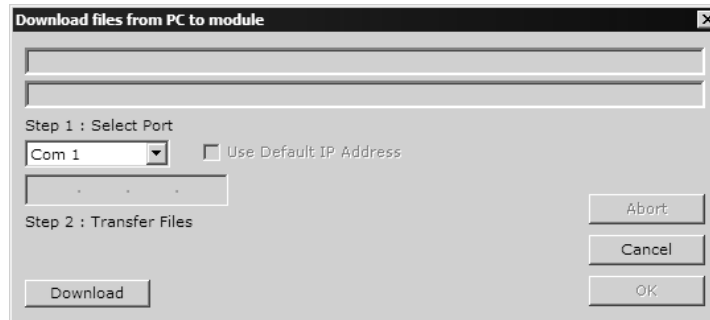

The download is complete when the OK button becomes active. When the download is complete, click **OK**.

6.3 Verify Data Exchange

Run Diagnostics Using ProSoft Configuration Builder

- 1 Connect the cable to the Debug Port of the PTQ-WA-PWP module. Ensure that power is applied to both modules.
- 2 Right-click on PTQ-WA-PWP and select Diagnostics.

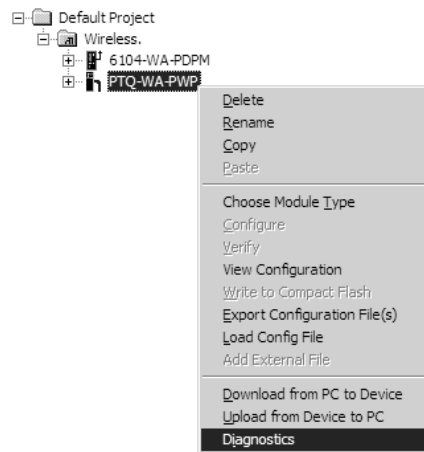

- 3 Select the appropriate Com port



- 4 Press "?" to display the Diagnostic menu.
- 5 Press "D" to display the Database menu.
- 6 Press "3" to show database registers beginning at 3000.

- Press the "S" key to refresh the database values. The circled values in the example should change each time you press the "S" key indicating that data is being passed between modules. If these values do not change, contact ProSoft Technical Support.

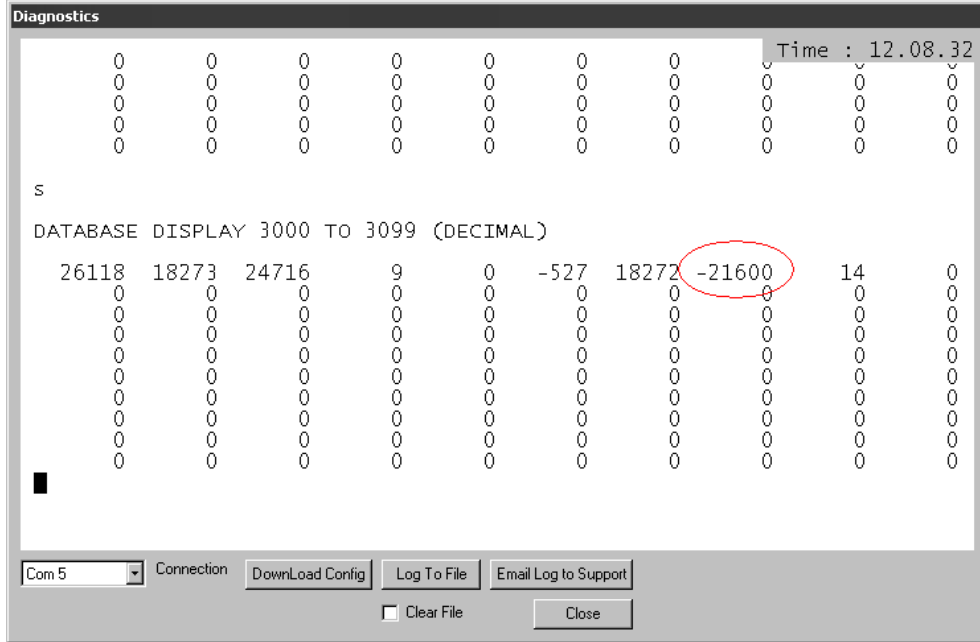

The data shown represents clock values that are being passed wirelessly from the 6104-WA-PDPM. The values are stored in five registers beginning with register 3005.

7 Diagnostics and Troubleshooting

In This Chapter

- ❖ Reading Status Data from the Module 71
- ❖ LED Status Indicators..... 83

The module provides information on diagnostics and troubleshooting in the following forms:

- Status data values are transferred from the module to the processor.
- Data contained in the module can be viewed through the Configuration/Debug port attached to a terminal emulator.
- LED status indicators on the front of the module provide information on the module's status.

7.1 Reading Status Data from the Module

The PTQ-WA-PWP module returns General Status Data and C/P Status Data blocks that can be used to determine the module's operating status. This data can be located in the module's database at registers at the location specified in the configuration. This data also available to the Quantum / Unity processor with each read block. Refer to Backplane Data Transfer (page 93) for information on the contents of this block.

7.1.1 Required Hardware

You can connect directly from your computer's serial port to the serial port on the module to view configuration information, perform maintenance, and send (upload) or receive (download) configuration files.

ProSoft Technology recommends the following minimum hardware to connect your computer to the module:

- 80486 based processor (Pentium preferred)
- 1 megabyte of memory
- At least one UART hardware-based serial communications port available. USB-based virtual UART systems (USB to serial port adapters) often do not function reliably, especially during binary file transfers, such as when uploading/downloading configuration files or module firmware upgrades.
- A null modem serial cable.

7.1.2 The Configuration/Debug Menu

The Configuration and Debug menu for this module is arranged as a tree structure, with the Main Menu at the top of the tree, and one or more sub-menus for each menu command. The first menu you see when you connect to the module is the Main menu.

Because this is a text-based menu system, you enter commands by typing the command letter from your computer keyboard in the diagnostic window in ProSoft Configuration Builder (PCB). The module does not respond to mouse movements or clicks. The command executes as soon as you press the command letter — you do not need to press **[Enter]**. When you type a command letter, a new screen will be displayed in your terminal application.

Using the Diagnostic Window in ProSoft Configuration Builder

To connect to the module's Configuration/Debug serial port:

- 1 Start PCB program with the application file to be tested. Right click over the module icon.

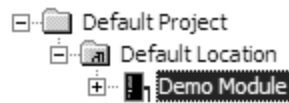

- 2 On the shortcut menu, choose Diagnostics.

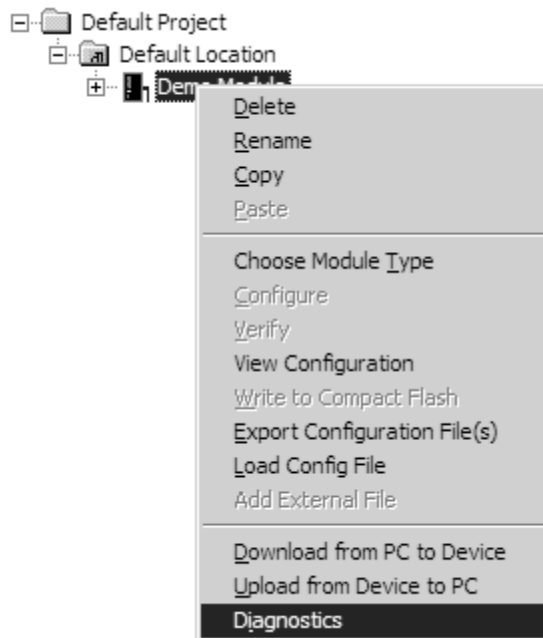

- 3 This action opens the Diagnostics dialog box. Press "?" to display the Main Menu.

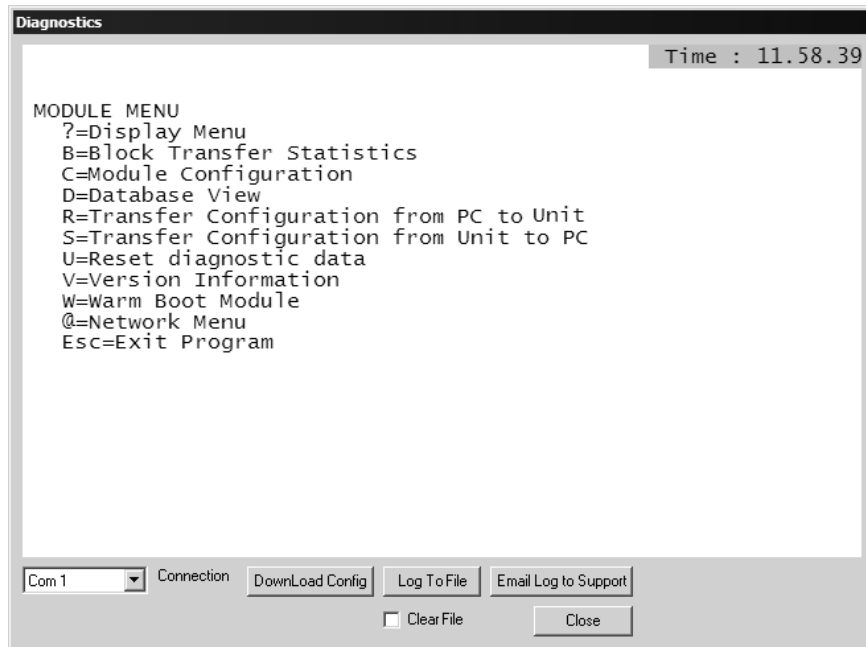

Important: The illustrations of configuration/debug menus in this section are intended as a general guide, and may not exactly match the configuration/debug menus in your own module.

If there is no response from the module, follow these steps:

- 1 Verify that the null modem cable is connected properly between your computer's serial port and the module. A regular serial cable will not work.
- 2 On computers with more than one serial port, verify that your communication program is connected to the same port that is connected to the module.

If you are still not able to establish a connection, contact ProSoft Technology for assistance.

Navigation

All of the sub-menus for this module contain commands to redisplay the menu or return to the previous menu. You can always return from a sub-menu to the next higher menu by pressing **[M]** on your keyboard.

The organization of the menu structure is represented in simplified form in the following illustration:

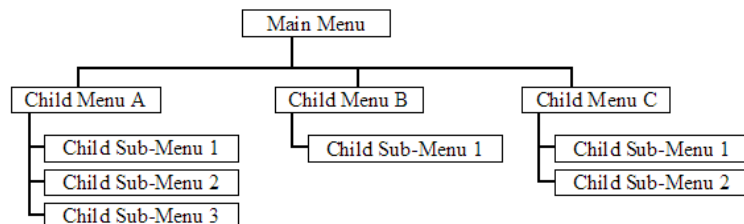

The remainder of this section shows you the menus available for this module, and briefly discusses the commands available to you.

Keystrokes

The keyboard commands on these menus are almost always non-case sensitive. You can enter most commands in lower case or capital letters.

The menus use a few special characters ([**?**], [**-**], [**+**], [**@**]) that must be entered exactly as shown. Some of these characters will require you to use the [**Shift**], [**Ctrl**] or [**Alt**] keys to enter them correctly. For example, on US English keyboards, enter the [**?**] command as [**Shift**]/.

Also, take care to distinguish capital letter [**I**] from lower case letter [**i**] (L) and number [**1**]; likewise for capital letter [**O**] and number [**0**]. Although these characters look nearly the same on the screen, they perform different actions on the module.

7.1.3 Main Menu

When you first connect to the module from your computer, your terminal screen will be blank. To activate the main menu, press the [**?**] key on your computer's keyboard. If the module is connected properly, the following menu will appear on your terminal screen:

Caution: Some of the commands available to you from this menu are designed for advanced debugging and system testing only, and can cause the module to stop communicating with the processor or with other devices, resulting in potential data loss or other failures. Only use these commands if you are specifically directed to do so by ProSoft Technology Technical Support staff. Some of these command keys are not listed on the menu, but are active nevertheless. Please be careful when pressing keys so that you do not accidentally execute an unwanted command.

```
WIRELESS COMMUNICATION MODULE MENU
?=Display Menu
B=Profibus Configuration
C=Module Configuration
D=Database View
P=Profibus Menu
R=Radio Menu
S=Transfer Configuration from Unit to PC
U=Reset status
V=Version Information
W=warm Boot Module
Y=PWP Menu
Z=SNTP Status
@=Network Menu
%=Map Data Menu
Esc=Exit Program
```

Redisplaying the Menu

Press [**?**] to display the current menu. Use this command when you are looking at a screen of data, and want to view the menu choices available to you.

Viewing Module Configuration

Press **[C]** to view the Module Configuration screen.

Use this command to display the current configuration and statistics for the module.

Opening the Database Menu

Press **[D]** to open the Database View menu. Use this menu command to view the current contents of the module's database.

Opening the Radio Menu

Press **[R]** to open the Radio menu. Use this command to view configuration and status for the module's onboard radio.

Transferring the Configuration File from PTQ module to PC

Press **[S]** to receive (download) the configuration file from the module to your PC.

Press **[Y]** to confirm the file transfer, and then follow the instructions on the terminal screen to complete the file transfer process.

After the file has been successfully downloaded, you can open and edit the file to change the module's configuration.

Resetting diagnostic data

Press **[U]** to reset the status counters for the client and/or servers in the module.

Viewing Version Information

Press **[V]** to view Version information for the module.

Use this command to view the current version of the software for the module, as well as other important values. You may be asked to provide this information when calling for technical support on the product.

Values at the bottom of the display are important in determining module operation. The Program Scan Counter value is incremented each time a module's program cycle is complete.

Tip: Repeat this command at one-second intervals to determine the frequency of program execution.

Warm Booting the Module

Caution: Some of the commands available to you from this menu are designed for advanced debugging and system testing only, and can cause the module to stop communicating with the processor or with other devices, resulting in potential data loss or other failures. Only use these commands if you are specifically directed to do so by ProSoft Technology Technical Support staff. Some of these command keys are not listed on the menu, but are active nevertheless. Please be careful when pressing keys so that you do not accidentally execute an unwanted command.

Press **[W]** from the Main Menu to warm boot (restart) the module. This command will cause the program to exit and reload, refreshing configuration parameters that must be set on program initialization. Only use this command if you must force the module to re-boot.

Opening the PWP Menu

Press **[Y]** to open the PWP Menu. Use this command to view configuration and status for the PWP protocol.

Viewing SNTP Status

Press **[N]** to view configuration information about the SNTP client.

```
SNTP CLIENT CONFIGURATION:
NTP SERVER IP : 0.0.0.0
DB REGISTER   : -1
TIME ZONE     : 0           USE DST       : No
TIME VALID    : No
REQUESTS      : 0           RESPONSES  : 0
COMPUTATIONS  : 0           TIME SET CNT : 0
TIMEOUT ERRS  : 0
```

Refer to SNTP Support for more information on configuring and using this function.

Opening the Network Menu

Press **[@]** to open the network menu. The network menu allows you to send, receive and view the WATTCP.CFG file that contains the IP, gateway and other network specification information. You can find more information about the commands on this menu in the Network Menu (page 80) section.

Opening the Map Data Menu

Press **[%]** to open the Map Data menu. Use this command to view settings and status of the database map.

Exiting the Program

Caution: Some of the commands available to you from this menu are designed for advanced debugging and system testing only, and can cause the module to stop communicating with the processor or with other devices, resulting in potential data loss or other failures. Only use these commands if you are specifically directed to do so by ProSoft Technology Technical Support staff. Some of these command keys are not listed on the menu, but are active nevertheless. Please be careful when pressing keys so that you do not accidentally execute an unwanted command.

Press **[Esc]** to restart the module and force all drivers to be loaded. The module will use the configuration stored in the module's Flash ROM to configure the module.

7.1.4 Database View Menu

Press **[D]** from the Main Menu to open the Database View menu. Use this menu command to view the current contents of the module's database. Press **[?]** to view a list of commands available on this menu.

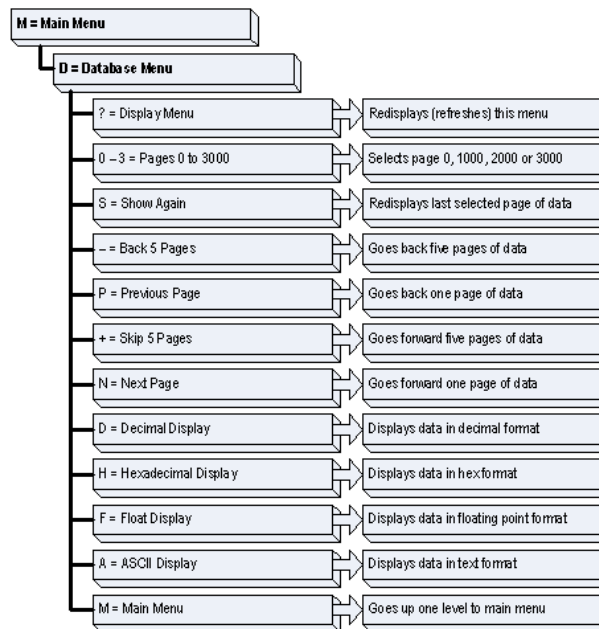

Viewing Register Pages

To view sets of register pages, use the keys described below:

Command	Description
[0]	Display registers 0 to 99
[1]	Display registers 1000 to 1099
[2]	Display registers 2000 to 2099

And so on. The total number of register pages available to view depends on your module's configuration.

Displaying the Current Page of Registers Again

DATABASE DISPLAY 0 TO 99 <DECIMAL>									
100	101	102	4	5	6	7	8	9	10
11	12	13	14	15	16	0	0	0	0
0	0	0	0	0	0	0	0	0	0
0	0	0	0	0	0	0	0	0	0
0	0	0	0	0	0	0	0	0	0
0	0	0	0	0	0	0	0	0	0
0	0	0	0	0	0	0	0	0	0
0	0	0	0	0	0	0	0	0	0
0	0	0	0	0	0	0	0	0	0
0	0	0	0	0	0	0	0	0	0
0	0	0	0	0	0	0	0	0	0

This screen displays the current page of 100 registers in the database.

Moving Back Through 5 Pages of Registers

Press **[-]** from the Database View menu to skip back to the previous 500 registers of data.

Viewing the Previous 100 Registers of Data

Press **[P]** from the Database View menu to display the previous 100 registers of data.

Skipping 500 Registers of Data

Hold down **[Shift]** and press **[=]** to skip forward to the next 500 registers of data.

Viewing the Next 100 Registers of Data

Press **[N]** from the Database View menu to select and display the next 100 registers of data.

Viewing Data in Decimal Format

Press **[D]** to display the data on the current page in decimal format.

Viewing Data in Hexadecimal Format

Press **[H]** to display the data on the current page in hexadecimal format.

Viewing Data in Floating Point Format

Press **[F]** from the Database View menu. Use this command to display the data on the current page in floating point format. The program assumes that the values are aligned on even register boundaries. If floating-point values are not aligned as such, they are not displayed properly.

Viewing Data in ASCII (Text) Format

Press **[A]** to display the data on the current page in ASCII format. This is useful for regions of the database that contain ASCII data.

Returning to the Main Menu

Press **[M]** to return to the Main Menu.

7.1.5 Radio Menu

Press **[R]** to open the Radio menu. Use this command to view configuration and status for the module's onboard radio.

```
RADIO MENU
C=Configuration
S=Status
1=Constant Radio Status Update
M=Return to Main Menu
```

Viewing Radio Configuration

Press **[C]** to view radio configuration. Use this command to view the port type, channel, data length and other radio configuration settings.

```
DRADIO STATIC CONFIGURATION:
Port Type      : 1          Own MAC Address: 00:10:C6:47:79:68
Own Channel    : 10         Own SSID:
Max Data Len  : 1508       Own Name: New
Encryption     : 0         Authentication : 1
TX Rate Ctrl  : 3          WEP Key Rollover: No
LED Levels    : 20 - 25 - 30 - 35
```

Viewing Radio Status

Press **[S]** to view the current operational status of the radio. Use this command to view connection and signal status, packets and bytes transferred, signal quality and errors.

```
DRADIO DRIVER STATUS:
Port Status = Connected IBSS SSID = NetworkWA
Transmit Rate = 11 MB Signal Quality = 83 dB
Signal Level = -19 dBm Noise Level = -102 dBm
PacketsIn = 12082 PacketsOut = 23737
BytesIn = 1932496 BytesOut = 3796798
ErrorsIn = 1 ErrorsOut = 559
PacketsDropped = 0 Channel # = 10
```

Continuously Monitoring Radio Status

Press **[1]** to monitor radio status continuously. Use this command to view the signal strength and noise level for the radio in real time.

```
Radio Monitor Enabled. Press any key to exit.  
Q= 48 dB SL= -46 dBm NL= -94 dBm  
Q= 48 dB SL= -46 dBm NL= -94 dBm  
Q= 49 dB SL= -46 dBm NL= -95 dBm  
Q= 50 dB SL= -45 dBm NL= -95 dBm  
Q= 50 dB SL= -45 dBm NL= -95 dBm  
Q= 49 dB SL= -46 dBm NL= -95 dBm  
Q= 49 dB SL= -46 dBm NL= -95 dBm  
Q= 49 dB SL= -46 dBm NL= -95 dBm
```

Important: When in continuous radio monitor mode, program execution will slow down. Only use this tool during a trouble-shooting session. Before disconnecting from the Config/Debug port, please be sure to press a key to disable the radio status monitor. This action will allow the module to resume its normal operating mode.

Returning to the Main Menu

Press **[M]** to return to the Main Menu.

7.1.6 Network Menu

The network menu allows you to send, receive and view the WATTCP.CFG file that contains the IP and gateway addresses, and other network specification information.

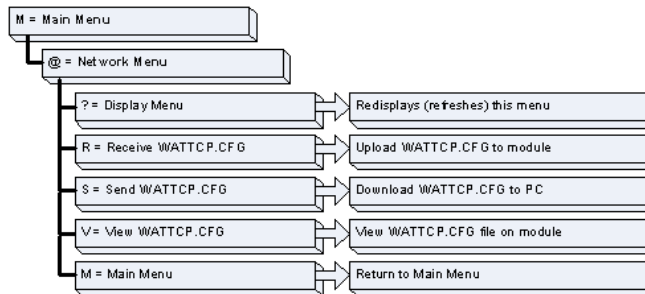

Transferring WATTCP.CFG to the module

Press **[R]** to transfer a new WATTCP.CFG file from the PC to the module. Use this command to change the network configuration for the module (for example, the module's IP address).

Press **[Y]** to confirm the file transfer, and then follow the instructions on the terminal screen to complete the file transfer process.

Transferring WATTCP.CFG to the PC

Press **[S]** to transfer the WATTCP.CFG file from the module to your PC.

Press **[Y]** to confirm the file transfer, and then follow the instructions on the terminal screen to complete the file transfer process.

After the file has been successfully transferred, you can open and edit the file to change the module's network configuration.

Viewing the WATTCP.CFG file on the module

Press **[V]** to view the module's WATTCP.CFG file. Use this command to confirm the module's current network settings.

```

Network Menu Selected
WATTCP.CFG FILE:
# ProLinx Communication Gateways, Inc.
#
# Default private class 3 address
my_ip=192.168.0.135
# Default class 3 network mask
netmask=255.255.255.0
# The gateway I wish to use
gateway=192.168.0.1
#
#Parameters used by the ProLinx Communication Gateways, Inc. module
#Local_Domain_Name=mycompany.com
#Password=PASSWORD

```

Returning to the Main Menu

Press **[M]** to return to the Main Menu.

7.1.7 PWP Menu

Press **[Y]** to open the PWP Menu. Use this command to view configuration and status for the PWP protocol.

```

RADIO PWP MENU
C=Producer/Consumer List Menu
G=Multicast Group List
S=Status Data Menu
?=Display Menu
M=Exit Menu

```

Opening the Producer/Consumer List Menu

Press **[C]** to open the Producer/Consumer List menu. Use this command to view the status of producers and consumers currently communicating on the network.

```

RADIO PWP PRODUCER/CONSUMER LIST 0 TO 9
P/C U/B ADDR REG_CNT SWP PROD_TIME IP ADDRESS EX_ID CFG_VER
P M 200 32 0 100 224.0.7.1 10 0.0
C M 0 32 0 100 224.0.7.1 11 0.0
P M 200 32 0 100 224.0.7.2 30 0.0
C M 32 32 0 100 224.0.7.2 31 0.0

```

Viewing the Multicast Group List

Press **[G]** to view the Multicast Group List. Use this command to see a list of IP addresses in the radio's configured multicast group.

```
RADIO MULTICAST GROUP LIST (Count=2):  
E0000701 224.0.7.1  
E0000702 224.0.7.2
```

Opening the Status Data Menu

Press **[S]** to open the Radio PWP Producer/Consumer Status List menu. Use this command to view communication status for each of the configured producers and consumers.

```
Status Data Menu Selected  
RADIO PWP PRODUCER/CONSUMER STATUS 0 TO 9  
S P MSG_COUNT MISS_COUNT REF_COUNT INVALID TM_SYNC SHORT LONG PROTO  
1 2 14604 0 0 0 0 0 0 0  
2 0 0 0 172126 0 0 0 0 0  
1 2 14604 0 0 0 0 0 0 0  
2 0 0 0 172126 0 0 0 0 0
```

Redisplaying the Menu

Press **[?]** to display the current menu. Use this command when you are looking at a screen of data, and want to view the menu choices available to you.

Returning to the Main Menu

Press **[M]** to return to the Main Menu.

7.1.8 Radio PWP Producer/Consumer List Menu

Press **[S]** to open the Radio PWP Producer/Consumer Status List menu. Use this command to view communication status for each of the configured producers and consumers.

```
RADIO PWP PRODUCER/CONSUMER STATUS MENU  
?=Display Menu  
S=Show Again  
-=Back 2 Pages  
P=Previous Page  
+=Skip 2 Pages  
N=Next Page  
?=Display Menu  
M=Return to RADIO PWP Main Menu
```

Redisplaying the Menu

Press **[?]** to display the current menu. Use this command when you are looking at a screen of data, and want to view the menu choices available to you.

Redisplaying the Current Page

Press **[S]** to display the current page of data.

Going Back Two Pages of Data

Press **[-]** from the Database View menu to skip back to the previous 200 registers of data.

Viewing the Previous Page of Data

Press **[P]** to display the previous page of data.

Going Ahead Two Pages of Data

Hold down **[Shift]** and press **[=]** to skip forward to the next 200 registers of data.

Viewing the Next Page of Data

Press **[N]** to display the next page of data.

Returning to the Previous Menu

Press **[M]** to return to the Previous Menu.

7.2 LED Status Indicators

The LEDs indicate the module's operating status as follows:

Module	Color	Status	Indication
DEBUG	Green	On	Data is being transferred between the module and a remote terminal using the Configuration/Debug port.
		Off	No data is being transferred on the Configuration/Debug port.
ERR 1	Red	Off	The PTQ module is working normally.
		On	The PTQ module has recognized an application error. This LED will also be turned on if any command presents an error.
ERR 2	N/A		Not used in Application
ACTIVE	Green	On	The LED is on when the module is recognizes a processor and is able to communicate if the [Backplane Data Movement] section specifies data transfer commands.
		Off	The LED is off when the module is unable to speak with the processor. The processor either absent or not running.
BAT LOW	Red	Off	The battery voltage is OK and functioning.
		On	The battery voltage is low or the battery is not present. The battery LED will illuminate briefly upon the first installation of the module or if the unit has been un-powered for an extended period of time. This behavior is normal, however should the LED come on in a working installation please contact ProSoft Technology.

If the APP, BP ACT and OK LEDs blink at a rate of every one-second, this indicates a serious problem with the module. Call ProSoft technical support to arrange for repairs.

7.2.1 RF LEDs

If the RF Signal Level LEDs are continuously asserted these will indicate the current quality level signal while the module is connected in either ad-hoc or infrastructure mode:

SIGNAL LED 1: 20

SIGNAL LED 2: 25

SIGNAL LED 3: 30

SIGNAL LED 4: 35

If the RF Signal Level LEDs are asserted for approximately 10 seconds and off for approximately 1 seconds it means that the module lost communication with the previously connected ad-hoc remote station (the asserted LEDs indicate the last measured quality level before disconnection).

If the RF Signal Level LEDs are off it means that either:

- 1 The module was initialized and has not established connection to any station
or
- 2 The module was disconnected from a previously connected Access Point.

RF Link: (Green) asserted continuously if module is:

- Connected ad-hoc
- Connected Infrastructure (ESS)
- Out of range Infrastructure (ESS)

If the RF Link LED is asserted for approximately 10 seconds and off for approximately 1 seconds it means that either:

- 1 The module was initialized and have not connected to any stations
- 2 The module lost communication with the previously connected ad-hoc remote station.

RF Data: (Green) Asserted when data is received or transmitted to the module

7.2.2 Troubleshooting

Use the following troubleshooting steps if you encounter problems when the module is powered up. If these steps do not resolve your problem, please contact ProSoft Technology Technical Support.

Processor Errors

Problem Description	Steps to take
Processor Fault	Verify that the module is plugged into the slot that has been configured for the module. Verify that the slot in the rack configuration has been set up correctly in the ladder logic.
Processor I/O LED flashes	This indicates a problem with backplane communications. Verify that all modules in the rack are configured in the ladder logic.

Module Errors

Problem Description	Steps to take
BP ACT LED remains off or blinks slowly	This indicates that backplane transfer operations are failing. Connect to the module's Configuration/Debug port to check this. To establish backplane communications, verify the following items: <ul style="list-style-type: none"> ▪ The processor is in Run mode. ▪ The backplane driver is loaded in the module. ▪ The module is configured for read and write block data transfer. ▪ The ladder logic handles all read and write block situations. ▪ The module is configured in the processor.
OK LED remains red	The program has halted or a critical error has occurred. Connect to the Configuration/Debug port to see if the module is running. If the program has halted, turn off power to the rack, remove the card from the rack and re-insert the card in the rack, and then restore power to the rack.

7.2.3 Clearing a Fault Condition

Typically, if the OK LED on the front of the module turns red for more than ten seconds, a hardware problem has been detected in the module, or the program has exited.

To clear the condition, follow these steps:

- 1 Turn off power to the rack
- 2 Remove the card from the rack
- 3 Verify that all jumpers are set correctly
- 4 If the module requires a Compact Flash card, verify that the card is installed correctly
- 5 Re-insert the card in the rack and turn the power back on
- 6 Verify the configuration data being transferred to the module from the Quantum / Unity processor.

If the module's OK LED does not turn green, verify that the module is inserted completely into the rack. If this does not cure the problem, contact ProSoft Technology Support.

8 Reference

In This Chapter

❖ Product Specifications	87
❖ Functional Overview	89
❖ RS-232 Configuration/Debug Port	99
❖ PWP Error/Status Data	100
❖ Exchange Configuration Form	101

8.1 Product Specifications

The In-Chassis Wireless Communication Module creates a powerful wireless connection between devices located remotely, and the Quantum / Unity processor. The efficient but powerful PWP protocol allows data exchange in one-to-one or one-to-many wireless scenarios.

ProSoft Wireless Protocol (PWP) offers versatility where a mix of control devices requires cooperation with each other. This involves sharing of information across the applications regardless of device or network type, often at high speed. Wireless bandwidth utilization is optimized by using efficient communication methods. The protocol supports Unicast, Broadcast and Multicast group messaging. The protocol is efficient because each device on the wireless network can produce these types of messages and each device determines which of these messages to consume.

ProSoft Wireless Protocol (PWP) offers versatility where a mix of control devices requires cooperation with each other. This involves sharing of information across the applications regardless of device or network type, often at high speed. Wireless bandwidth utilization is optimized by using efficient communication methods. The protocol supports Unicast, Broadcast and Multicast group messaging. The protocol is efficient because each device on the wireless network can produce these types of messages and each device determines which of these messages to consume.

General Specifications

- Single Slot - Quantum backplane compatible
- The module is recognized as an Options module and has access to PLC memory for data transfer
- Configuration data is stored in non-volatile memory in the ProTalk® module
- Configuration software for Microsoft Windows XP, 2000 and NT is included with the module
- Up to four modules can be placed in a rack
- Local rack - The module must be placed in the same rack as processor

- Compatible with common Quantum programming tools: UnityPro XL, Concept, ProWORX
- Quantum data types supported: 3x, 4x
- High speed data transfer across backplane provides quick data update times
- Sample ladder file available

8.1.1 Hardware Specifications

Specification	Value
Backplane Current Load	800 mA @ 5 V
Operating Temperature	0 to 60°C (32 to 140°F)
Storage Temperature	-40 to 85°C (-40 to 185°F)
Relative Humidity	5% to 95% (non-condensing)
Vibration	Sine vibration 4-100 Hz in each of the 3 orthogonal axes
Shock	30G, 11 mSec. in each of the 3 orthogonal axes
LED Indicators	Module Status Backplane Transfer Status Debug/Config Port Activity LED RF Link RF Data Four Level RF Signal Quality
Configuration Serial Port (Debug/ Config)	DB-9M PC Compatible RS-232 only No hardware handshaking

Functional Specifications

The ProSoft Wireless Protocol allows one controller to produce or send an area of its memory onto a network at a specified rate. It also allows another controller to consume or receive this data. Each data message contains a data sample, or snapshot, of a specific portion of the producing node's memory. Data messages are uniquely identified so that consuming nodes can relate the incoming data with a specific configuration (known as an exchange) which describes key characteristics of the data sample. A node can contain a number of these exchanges, so that it may be both a consumer of some exchanges and a producer of others at the same time.

Periodic Data Services provide an efficient mechanism which allows the repeated transmission of a set of variables from a controller which *produces* data, to one or more controllers which *consume* the data. Significant features of the Periodic Data Service include:

- A single request for data from a consumer controller can cause data packets to be sent repetitively from the producer.
- The set of data variables to be sent periodically can be pre-defined so that the controller starts sending the data as soon as it is initialized.
- Data can be sent to the specific node that requested it, or simultaneously to a group of nodes.
- Periodic Data Services utilize a low level protocol (UDP/IP) which requires less overhead than fully acknowledged stream oriented protocols.

Includes ProSoft Configuration Builder (PSW-PCB) configuration software.

General Radio Specifications

Specification	Value
Frequency	2.4 GHz band (2400 to 2483.5 MHz)*
Wireless medium	DSSS - Direct Sequence Spread Spectrum (802.11 b)
Output power	32 mW (15 dBm)
Channel data rates	11, 5.5, 2, 1 Mbps
Channels - user selectable	11 - North America 13 - Europe** 14 - Japan
Security	PWP + WEP 64/128 Encryption with WEP key rollover management
Antenna Ports	Two RP-SMA connectors, automatic antenna diversity
Bit Error Rate (BER)	Better than 10 ⁻⁵

Range / Transmit Rate	High Speed 11 Mbps	Medium Speed 5.5 Mbps	Standard Speed 2 Mbps	Low Speed 1 Mbps
Open Office Environment	160m (525 ft.)	270 m (885 ft.)	400 m (1300 ft.)	550 m (1750 ft)
Semi-Open Office Environment	50 m (165 ft.)	70 m (230 ft.)	90 m (300 ft.)	115 m (375 ft.)
Closed Office	25 m (80 ft.)	35 m (115 ft.)	40 m (130 ft.)	50 m (165 ft)
Receiver Sensitivity	-83 dBm	-87 dBm	-91 dBm	-94 dBm

General range guidelines (actual results may vary)

* Varies with country regulation

** Some European countries such as France allow fewer channels

8.2 Functional Overview

The ProSoft Wireless Protocol (PWP) can be used to interface many different protocols with PWP devices. PWP provides a means by which one controller produces or sends an area of its memory onto a network at a specified rate. It also describes the means for another controller to consume or receive this data. Each data message contains a data sample, or snap-shot, of a specific portion of the producing node's memory. Data messages are uniquely identified so that consuming nodes can relate the incoming data with a specific configuration (known as an exchange) which describes key characteristics of the data sample. A node can contain a number of these exchanges, so that it may be both a consumer of some exchanges and a producer of others at the same time.

Periodic Data Services provide an efficient mechanism which allows the repeated transmission of a set of variables from a controller which produces data, to one or more controllers which consume the data. Significant features of the Periodic Data Service include:

- A single request for data from a consumer controller can cause data packets to be sent repetitively from the producer.

- The set of data variables to be sent periodically can be pre-defined so that the controller starts sending the data as soon as it is initialized.
- Data can be sent to the specific node that requested it, or simultaneously to a group of nodes.
- Periodic Data Services utilize a low level protocol (UDP/IP) which requires less overhead than fully acknowledged stream oriented protocols.

8.2.1 Underlying Protocol Requirements and Constraints

PWP protocol messages are classified as either command or data messages. PWP has been designed to operate on a message based, connectionless network transport layer, such as the internet UDP/IP protocol. Each protocol message is sent to a specific network access point (UDP port) on the destination node(s). Command messages can be used to monitor and control the operation of PWP on the destination node. Command messages usually derived from SCADA systems are not currently supported. Data messages are individually configured to send a sample of data at a fixed periodic rate. Each data message that a node sends or receives is associated with a specific identifier, which uniquely defines the configuration of the data sample. This configuration is referred to as an exchange. PWP allows the configuration of exchanges which are sent to a single destination address (IP Unicast addressing), a group of addresses (IP Multicast addressing), or to all PWP nodes (IP Broadcast addressing). An assigned set of 32 IP Multicast addresses has been defined for use by applications requiring the transmission of data exchanges to a group of nodes. The following tables show the defined network parameters for PWP.

Assigned UDP Network Ports

Parameter	UDP Port
Command Port	7937. (1F01H)
Data Port	18246. (4746H)

Multicast Address Assignments

Parameter	IP Address
Group 1	224.0.7.1
Group 2	224.0.7.2
...	...
Group 32	224.0.7.32

PWP provides a means by which one controller produces or sends an area of its memory onto a network at a specified rate. It also describes the means for another controller to consume or receive this data. Each data message contains a data sample, or snap-shot, of a specific portion of the producing node's memory. Data messages are uniquely identified so that consuming nodes can relate the incoming data with a specific configuration (known as an exchange) which describes key characteristics of the data sample. A controller can contain a number of these exchanges, so that it may be both a consumer of some exchanges, and a producer of others at the same time.

The user defines the data to be produced and consumed in a configuration file downloaded to the module. The command service is limited to responding to requests from other units. The module will not initiate port 7937 commands. The driver interfaces with a common internal database in the module. This permits the sharing of data across many different types of networks. The following illustration shows the functionality of the PWP driver when interfaced with serial communication based and 802.11b wireless networks:

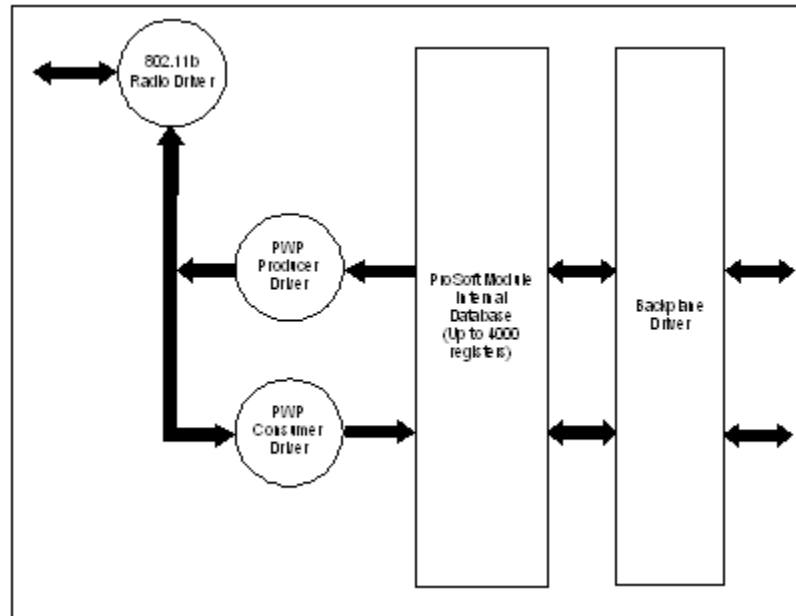

In order to use these functions, an exchange must first exist in the module's exchange list defining the database and register count. If the production/consumption time is set to zero, the exchange will never be produced or consumed and will only be valid for command processing. These functions should be used for data that is not time critical and does not require periodic updating. The maximum length of the message is limited to 1360 bytes.

8.2.2 PWP Producer

The PWP driver will generate produced data as defined in the user configuration exchange list. This data is derived from the module's internal database and is produced at the set interval defined in the exchange list. This data can be broadcast to all nodes, sent to a specific multicast group or sent to a specific node on the network. Up to 700 database registers can be transferred in a single produced message. Therefore, to transfer the whole database would only require 6 messages (4000 word registers in the module's database).

Central to the functionality of the module is the internal database. This database is shared between all the drivers in the module and is used as a conduit to pass information from one device on one network to one or more devices on another network. This permits data from devices on one communication port to be viewed and controlled by devices on another port.

The producer functionality provided in the PWP driver transfers portions of the module's database to other PWP nodes on the network. The following diagram describes the flow of data between the Producer, the internal database and the remote Consumer device:

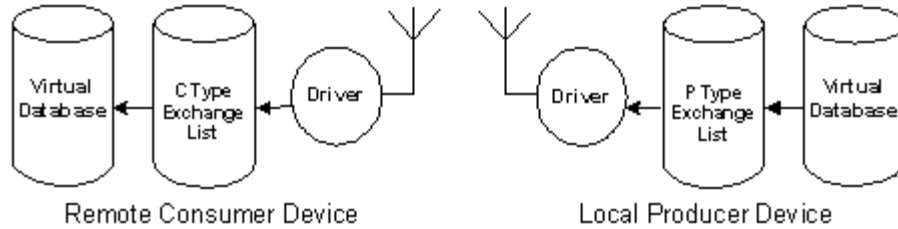

8.2.3 PWP Consumer

The PWP driver will consume data as defined in the user configuration exchange list. This data is derived from other nodes on the network and is placed in the module's internal database. If a consumer exchange is not received at the specified timeout, the driver will update the status of the exchange. When the driver again receives the exchange, the status will be updated. Exchanges received by the consumer driver that are not defined in the exchange list will be discarded. Up to 700 words of data can be consumed in a single message. Therefore, to fill the whole database with values would only require 6 exchanges (4000 word registers in the module's database).

The consumer functionality provided in the PWP driver transfers data from other nodes on the network into the module's database. The following diagram describes the flow of data between the Consumer, the internal database and the remote Producer device:

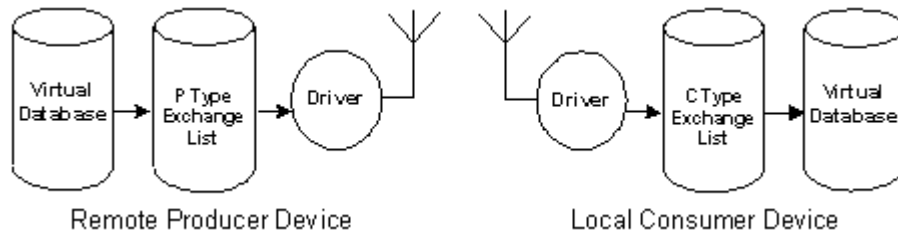

8.2.4 General Concepts

The following topics describe several concepts that are important for understanding the operation of the PTQ-WA-PWP module.

On power up the module begins performing the following logical functions:

- 1 Initialize hardware components
 - o Initialize Quantum / Unity backplane driver
 - o Test and Clear all RAM
 - o Initialize the serial communication ports

- 2 Reads configuration from Compact Flash Disk
- 3 Initialize Module Register space
- 4 Enable Slave Driver on selected ports

After the module has received the Module Configuration, the module will begin communicating with other nodes on the network, depending on the configuration.

Main Logic Loop

Upon completing the power up configuration process, the module enters an infinite loop that performs the functions shown in the following diagram.

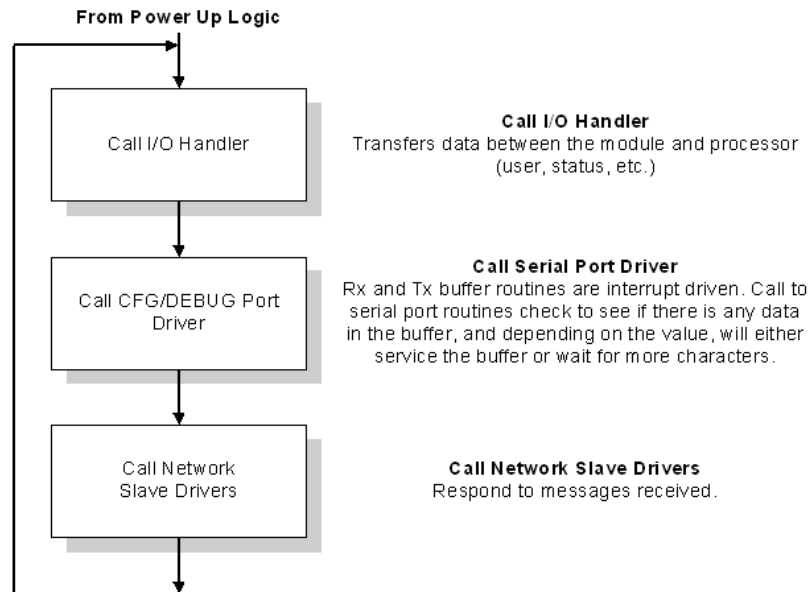

Quantum / Unity Processor Not in Run

Whenever the module detects that the processor has gone out of the Run mode (that is, Fault or PGM), backplane communications will halt between processor and module but not on the WA-PWP network. When the processor is returned to a running state, the module will resume communication with the Processor.

Backplane Data Transfer

The PTQ-WA-PWP module communicates directly over the Quantum / Unity backplane. Data is paged between the module and the Quantum / Unity processor across the backplane using the module's input and output images. The update frequency of the images is determined by the scheduled scan rate defined by the user for the module and the communication load on the module. Typical updates are in the range of 1 to 10 milliseconds.

This bi-directional transference of data is accomplished by the module filling in data in the module's input image to send to the processor. Data in the input image is placed in the Controller Tags in the processor by the ladder logic. The input image for the module is set to 250 words. This large data area permits fast throughput of data between the module and the processor.

The processor inserts data into the module's output image to transfer to the module. The module's program extracts the data and places it in the module's internal database. The output image for the module is set to 248 words. This large data area permits fast throughput of data from the processor to the module.

The following illustration shows the data transfer method used to move data between the Quantum / Unity processor, the PTQ-WA-PWP module and the PWP network.

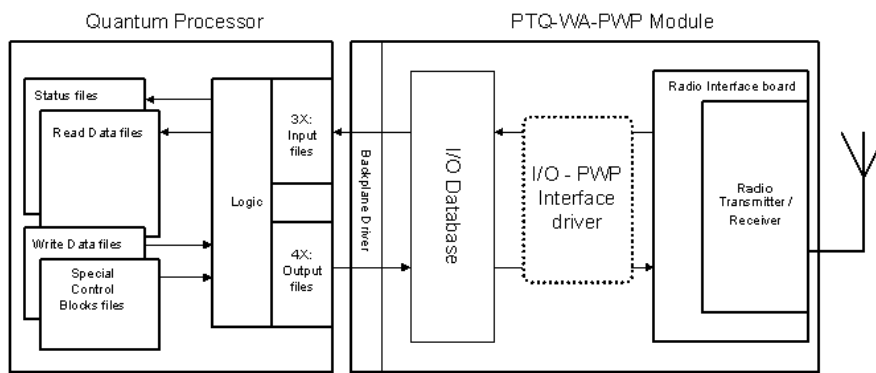

All data transferred between the module and the processor over the backplane is through the input and output images. Ladder logic must be written in the Quantum / Unity processor to interface the input and output image data with data defined in the Controller Tags. All data used by the module is stored in its internal database. The following illustration shows the layout of the database:

Module's Internal Database Structure

4000 registers for user data

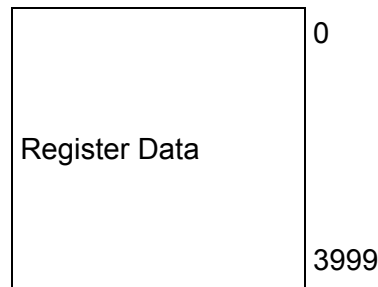

Data contained in this database is paged through the input and output images by coordination of the Quantum / Unity ladder logic and the PTQ-WA-PWP module's program. Up to 248 words of data can be transferred from the module to the processor at a time. Up to 247 words of data can be transferred from the processor to the module. The read and write block identification codes in each data block determine the function to be performed or the content of the data block. The block identification codes used by the module are listed in the following tables:

Block Range	Descriptions
-1 or 0	Empty Data Blocks
1 to 20	Data Read or Write Blocks
2000	CP Status Data
9250	General Status Data
9998	Warm-boot control block (same effect as 9999)
9999	Cold-boot control block

Each image has a defined structure depending on the data content and the function of the data transfer.

8.2.5 Normal Data Transfer

Normal data transfer includes the paging of the user data found in the module's internal database in registers 0 to 3999 and the status data. These data are transferred through read (input image) and write (output image) blocks. Refer to **Module Configuration** for a description of the data objects used with the blocks and the ladder logic required. The structure and function of each block is discussed in the following topics.

Read Block

These blocks of data transfer information from the module to the Quantum / Unity processor and transfer output (control) data sent to the module from the remote master unit. The structure of the input image used to transfer this data is shown in the following table.

Words	Descriptions
0	Command/Control Sequence Trigger
1	Command/Control code
2 to 63	Command/Control data
64 to n	Input data

The Read Block ID is an index value used to determine the location of where the data will be placed in the Quantum / Unity processor controller tag array of module read data. Each transfer can move up to 200 words (block offsets 2 to 201) of data. In addition to moving user data, the block also contains status data for the module. This last set of data is transferred with each new block of data and can be used for module diagnostics.

The Write Block ID associated with the block requests data from the Quantum / Unity processor. Under normal, program operation, the module sequentially sends read blocks and requests write blocks. For example, if three read and two write blocks are used with the application, the sequence will be as follows:

R1W1 → R2W2 → R3W1 → R1W2 → R2W1 → R3W2 → R1W1 →

This sequence will continue until interrupted by other write block numbers sent by the controller or operator control through the module's Configuration/Debug port.

Write Block

These blocks of data transfer information from the Quantum / Unity processor to the module and source the input (monitored) data to be used by the remote master. The structure of the output image used to transfer this data is shown in the following table.

Words	Descriptions
0	Command/Control Sequence Trigger
1	Command/Control code
2 to 63	Command/Control data
64 to n	Input data

The Write Block ID is an index value used to determine the location in the module's database where the data will be placed. Each transfer can move up to 200 words (block offsets 1 to 200) of data.

8.2.6 Command Control Blocks

Command control blocks are special blocks used to control the module. The current version of the software supports the following command control blocks.

Code	Description
2000	C/P status data
9250	General status data
9998	Warm boot module (same affect as 9999)
9999	Cold boot module

C/P Status Data (Block 2000)

Block 2000 Request

Words	Description
0	Command/Control Sequence Trigger
1	2000 Command Block ID
2	Number of C/P messages (1 to 4)
3	First C/P index (0 to 99)
4 to 63	Reserved
64 to n	Output data

Block 2000 Response

Words	Description
0	Command/Control Sequence Trigger
1	2000 Command Block ID
2	Number of C/P messages (0 to 4) Will be set to 0 if error in request.
3	First C/P index (0 to 99)
4 to 17	C/P Status Data
18 to 31	C/P Status Data
32 to 45	C/P Status Data

Words	Description
46 to 59	C/P Status Data
60 to 63	Reserved
64 to n	Output data

Block 2000 C/P Status Data Format

Words	Description
0	Status (0=invalid, 1=producing/healthy, 2=pending/unhealthy)
1	Status bit mapped (bit0=error or invalid, bit1=not time synchronized, bits 2 to 15 reserved)
2	Number of times C/P (LSW)
3	Number of times C/P (MSW)
4	Missed count (LSW)
5	Missed count (MSW)
6	Refresh count error (LSW)
7	Refresh count error (MSW)
8	Invalid error bit set by producer
9	Time sync error set by producer
10	Short message error in exchange
11	Long message error in exchange
12	Protocol PVN not set to 1
13	Configuration signature not set correctly

General Status (Block 9250)

Block 9250 Request Block (General Status)

Words	Description
0	Command/Control Sequence Trigger
1	9250 Command code value
2 to 63	Command/Control data
64 to n	Output data

Block 9250 Response Block (General Status)

Words	Description
0	Command/Control Sequence Trigger
1	9250 Command code value
2	Program scan counter
3	Product code bytes 0 & 1
4	Product code bytes 2 & 3
5	Revision bytes 0 & 1
6	Revision bytes 2 & 3
7	Op bytes 0 & 1
8	Op bytes 2 & 3
9	Run bytes 0 & 1
10	Run bytes 2 & 3
11	Block write counter
12	Block read counter

Words	Description
13	Block parse counter
14	Block error counter
15	SNTP valid time
16	SNTP request count
17	SNTP response count
18	SNTP computation count
19	SNTP set count
20	SNTP timeout error count
21	SNTP seconds (LSW)
22	SNTP seconds (MSW)
23	SNTP microseconds (LSW)
24	SNTP microseconds (MSW)
25	Radio Packets In (LSW)
26	Radio Packets In (MSW)
27	Radio Packets Out (LSW)
28	Radio Packets Out (MSW)
29	Radio Bytes In (LSW)
30	Radio Bytes In (MSW)
31	Radio Bytes Out (LSW)
32	Radio Bytes Out (MSW)
33	Radio Errors In (LSW)
34	Radio Errors In (MSW)
35	Radio Errors Out (LSW)
36	Radio Errors Out (MSW)
37	Radio Packets Dropped (LSW)
38	Radio Packets Dropped (MSW)
39	Radio Port Status
40	Radio LED output & Signal LED output
41	Radio Link & Data LED output
42	SSID bytes 0 & 1
43	SSID bytes 2 & 3
44	SSID bytes 4 & 5
45	SSID bytes 6 & 7
46	SSID bytes 8 & 9
47	SSID bytes 10 & 11
48	SSID bytes 12 & 13
49	SSID bytes 14 & 15
50	SSID bytes 16 & 17
51	SSID bytes 18 & 19
52	SSID bytes 20 & 21
53	SSID bytes 22 & 23

Words	Description
54	SSID bytes 24 & 25
55	SSID bytes 26 & 27
56	SSID bytes 28 & 29
57	SSID bytes 30 & 31
58	SSID bytes 32 & 33
59	Radio Tx rate
60	Radio Comm Quality
61	Radio Signal Level
62	Radio Noise Level
63	Radio Channel Number

Software Reset (Block 9998/9999)

This block is sent from the Quantum / Unity processor to the module (output image) when the module is required to perform a warm-boot (software reset) operation. This block is commonly sent to the module any time configuration data modifications are made. This will force the module to read the new configuration information and to restart. The structure of the control block is shown in the following table.

Offset	Description	Length
0	9998 or 9999	1
1 to <i>n</i>	Spare	247

Because many of the parameters set in the configuration file require the program to restart, this function works the same as the cold-boot function. It will cause the module to exit and restart the program.

8.3 RS-232 Configuration/Debug Port

This port is physically a DB-9 connection. This port permits a PC based terminal emulation program to view configuration and status data in the module and to control the module. The cable for communications on this port is shown in the following diagram:

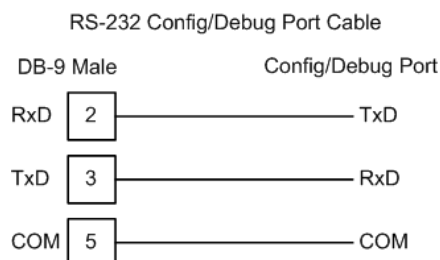

The Ethernet port on this module (if present) is inactive.

8.4 PWP Error/Status Data

There is a 14-word register data area for each exchange. The following table describes each value stored for an exchange:

Status Value	Description
Configuration State	This word register defines the configuration state of the exchange as follows: 0=Invalid, 1-producing/healthy, 2-pending/unhealthy
Production Status	This word is bit mapped with the following definition of the production status: bit0=err/invalid, bit1=not time sync
Message count	This double-word value counts the number of times the exchange has been produced or consumed.
Number of times missed	This double-word value counts the number of data production packets missed. This counter is incremented each time the Request ID in the received produced message is greater than 1 more than the last Request ID received (adjusted for roll-over).
Number of refresh errors	This double-word value counts the number of refresh errors that have been encountered by the driver. A refresh error occurs when the produced exchange does not arrive to the consumer within the set P/C time. This will only be valid for consumer exchanges.
Invalid bit set by producer count	This word counter is incremented each time the producer indicates that the produced data exchange is invalid.
Time sync bit set by producer count	This word counter is incremented each time the producer indicates that the time sync bit is set in a produced message. The data in the message may be valid.
Short message count	This word counter is incremented each time the message being consumed is less than that configured in the exchange.
Long message count	This word counter is incremented each time the message being consumed is greater than that configured for the exchange. The data will be consumed for the length set in the exchange. The remaining will be discarded.
Protocol version number error count	This word counter is incremented each time for each message the protocol version is not set correctly. The protocol states that only a value of 1 is acceptable. The message will not be consumed.
Configuration signature error count	This word counter is incremented each time for each message where the configuration version information (major and minor) are not acceptable for the configured exchange. The data will not be consumed.

The data area is initialized with zeros whenever the module is initialized. This occurs during a cold-start (power-on), reset (reset push-button pressed) or a warm-boot operation (commanded or loading of new configuration).

9 Support, Service & Warranty

In This Chapter

- ❖ How to Contact Us: Technical Support..... 103
- ❖ Return Material Authorization (RMA) Policies and Conditions..... 104
- ❖ LIMITED WARRANTY..... 105

ProSoft Technology, Inc. (ProSoft) is committed to providing the most efficient and effective support possible. Before calling, please gather the following information to assist in expediting this process:

- 1 Product Version Number
- 2 System architecture
- 3 Network details

If the issue is hardware related, we will also need information regarding:

- 1 Module configuration and contents of file
 - Module Operation
 - Configuration/Debug status information
 - LED patterns
- 2 Information about the processor and user data files as viewed through and LED patterns on the processor.
- 3 Details about the serial devices interfaced, if any.

9.1 How to Contact Us: Technical Support

Internet	Web Site: http://www.prosoft-technology.com/support E-mail address: support@prosoft-technology.com
-----------------	---

Asia Pacific

+603.7724.2080, support.asia@prosoft-technology.com
Languages spoken include: Chinese, English

Europe (location in Toulouse, France)

+33 (0) 5.34.36.87.20, support.EMEA@prosoft-technology.com
Languages spoken include: French, English

North America/Latin America (excluding Brasil) (location in California)

+1.661.716.5100, support@prosoft-technology.com
Languages spoken include: English, Spanish

For technical support calls within the United States, an after-hours answering system allows pager access to one of our qualified technical and/or application support engineers at any time to answer your questions.

Brasil (location in Sao Paulo)

+55-11-5084-5178, eduardo@prosoft-technology.com
Languages spoken include: Portuguese, English

9.2 Return Material Authorization (RMA) Policies and Conditions

The following RMA Policies and Conditions (collectively, "RMA Policies") apply to any returned Product. These RMA Policies are subject to change by ProSoft without notice. For warranty information, see "Limited Warranty". In the event of any inconsistency between the RMA Policies and the Warranty, the Warranty shall govern.

9.2.1 All Product Returns:

- a) In order to return a Product for repair, exchange or otherwise, the Customer must obtain a Returned Material Authorization (RMA) number from ProSoft and comply with ProSoft shipping instructions.
- b) In the event that the Customer experiences a problem with the Product for any reason, Customer should contact ProSoft Technical Support at one of the telephone numbers listed above (page 103). A Technical Support Engineer will request that you perform several tests in an attempt to isolate the problem. If after completing these tests, the Product is found to be the source of the problem, we will issue an RMA.
- c) All returned Products must be shipped freight prepaid, in the original shipping container or equivalent, to the location specified by ProSoft, and be accompanied by proof of purchase and receipt date. The RMA number is to be prominently marked on the outside of the shipping box. Customer agrees to insure the Product or assume the risk of loss or damage in transit. Products shipped to ProSoft using a shipment method other than that specified by ProSoft or shipped without an RMA number will be returned to the Customer, freight collect. Contact ProSoft Technical Support for further information.
- d) A 10% restocking fee applies to all warranty credit returns whereby a Customer has an application change, ordered too many, does not need, etc.

9.2.2 Procedures for Return of Units Under Warranty:

A Technical Support Engineer must approve the return of Product under ProSoft's Warranty:

- a) A replacement module will be shipped and invoiced. A purchase order will be required.
- b) Credit for a product under warranty will be issued upon receipt of authorized product by ProSoft at designated location referenced on the Return Material Authorization.

9.2.3 Procedures for Return of Units Out of Warranty:

- a) Customer sends unit in for evaluation
- b) If no defect is found, Customer will be charged the equivalent of \$100 USD, plus freight charges, duties and taxes as applicable. A new purchase order will be required.

- c) If unit is repaired, charge to Customer will be 30% of current list price (USD) plus freight charges, duties and taxes as applicable. A new purchase order will be required or authorization to use the purchase order submitted for evaluation fee.

The following is a list of non-repairable units:

- 3150 - All
- 3750
- 3600 - All
- 3700
- 3170 - All
- 3250
- 1560 - Can be repaired, only if defect is the power supply
- 1550 - Can be repaired, only if defect is the power supply
- 3350
- 3300
- 1500 - All

9.2.4 Purchasing Warranty Extension:

- a) ProSoft's standard warranty period is three (3) years from the date of shipment as detailed in "Limited Warranty (page 105)". The Warranty Period may be extended at the time of equipment purchase for an additional charge, as follows:
- Additional 1 year = 10% of list price
 - Additional 2 years = 20% of list price
 - Additional 3 years = 30% of list price

9.3 LIMITED WARRANTY

This Limited Warranty ("Warranty") governs all sales of hardware, software and other products (collectively, "Product") manufactured and/or offered for sale by ProSoft, and all related services provided by ProSoft, including maintenance, repair, warranty exchange, and service programs (collectively, "Services"). By purchasing or using the Product or Services, the individual or entity purchasing or using the Product or Services ("Customer") agrees to all of the terms and provisions (collectively, the "Terms") of this Limited Warranty. All sales of software or other intellectual property are, in addition, subject to any license agreement accompanying such software or other intellectual property.

9.3.1 What Is Covered By This Warranty

- a) *Warranty On New Products:* ProSoft warrants, to the original purchaser, that the Product that is the subject of the sale will (1) conform to and perform in accordance with published specifications prepared, approved and issued by ProSoft, and (2) will be free from defects in material or workmanship; provided these warranties only cover Product that is sold as new. This Warranty expires three years from the date of shipment (the "Warranty Period"). If the Customer discovers within the Warranty Period a failure of the Product to conform to specifications, or a defect in material or workmanship of the Product, the Customer must promptly notify ProSoft by fax, email or telephone. In no event may that notification be received by ProSoft later than 39 months. Within a reasonable time after notification, ProSoft will correct any failure of the Product to conform to specifications or any defect in material or workmanship of the Product, with either new or used replacement parts. Such repair, including both parts and labor, will be performed at ProSoft's expense. All warranty service will be performed at service centers designated by ProSoft.
- b) *Warranty On Services:* Materials and labor performed by ProSoft to repair a verified malfunction or defect are warranted in the terms specified above for new Product, provided said warranty will be for the period remaining on the original new equipment warranty or, if the original warranty is no longer in effect, for a period of 90 days from the date of repair.

9.3.2 What Is Not Covered By This Warranty

- a) ProSoft makes no representation or warranty, expressed or implied, that the operation of software purchased from ProSoft will be uninterrupted or error free or that the functions contained in the software will meet or satisfy the purchaser's intended use or requirements; the Customer assumes complete responsibility for decisions made or actions taken based on information obtained using ProSoft software.
- b) This Warranty does not cover the failure of the Product to perform specified functions, or any other non-conformance, defects, losses or damages caused by or attributable to any of the following: (i) shipping; (ii) improper installation or other failure of Customer to adhere to ProSoft's specifications or instructions; (iii) unauthorized repair or maintenance; (iv) attachments, equipment, options, parts, software, or user-created programming (including, but not limited to, programs developed with any IEC 61131-3, "C" or any variant of "C" programming languages) not furnished by ProSoft; (v) use of the Product for purposes other than those for which it was designed; (vi) any other abuse, misapplication, neglect or misuse by the Customer; (vii) accident, improper testing or causes external to the Product such as, but not limited to, exposure to extremes of temperature or humidity, power failure or power surges; or (viii) disasters such as fire, flood, earthquake, wind and lightning.

- c) The information in this Agreement is subject to change without notice. ProSoft shall not be liable for technical or editorial errors or omissions made herein; nor for incidental or consequential damages resulting from the furnishing, performance or use of this material. The user guide included with your original product purchase from ProSoft contains information protected by copyright. No part of the guide may be duplicated or reproduced in any form without prior written consent from ProSoft.

9.3.3 Disclaimer Regarding High Risk Activities

Product manufactured or supplied by ProSoft is not fault tolerant and is not designed, manufactured or intended for use in hazardous environments requiring fail-safe performance including and without limitation: the operation of nuclear facilities, aircraft navigation of communication systems, air traffic control, direct life support machines or weapons systems in which the failure of the product could lead directly or indirectly to death, personal injury or severe physical or environmental damage (collectively, "high risk activities"). ProSoft specifically disclaims any express or implied warranty of fitness for high risk activities.

9.3.4 Intellectual Property Indemnity

Buyer shall indemnify and hold harmless ProSoft and its employees from and against all liabilities, losses, claims, costs and expenses (including attorney's fees and expenses) related to any claim, investigation, litigation or proceeding (whether or not ProSoft is a party) which arises or is alleged to arise from Buyer's acts or omissions under these Terms or in any way with respect to the Products. Without limiting the foregoing, Buyer (at its own expense) shall indemnify and hold harmless ProSoft and defend or settle any action brought against such Companies to the extent based on a claim that any Product made to Buyer specifications infringed intellectual property rights of another party. ProSoft makes no warranty that the product is or will be delivered free of any person's claiming of patent, trademark, or similar infringement. The Buyer assumes all risks (including the risk of suit) that the product or any use of the product will infringe existing or subsequently issued patents, trademarks, or copyrights.

- a) Any documentation included with Product purchased from ProSoft is protected by copyright and may not be duplicated or reproduced in any form without prior written consent from ProSoft.
- b) ProSoft's technical specifications and documentation that are included with the Product are subject to editing and modification without notice.
- c) Transfer of title shall not operate to convey to Customer any right to make, or have made, any Product supplied by ProSoft.
- d) Customer is granted no right or license to use any software or other intellectual property in any manner or for any purpose not expressly permitted by any license agreement accompanying such software or other intellectual property.

- e) Customer agrees that it shall not, and shall not authorize others to, copy software provided by ProSoft (except as expressly permitted in any license agreement accompanying such software); transfer software to a third party separately from the Product; modify, alter, translate, decode, decompile, disassemble, reverse-engineer or otherwise attempt to derive the source code of the software or create derivative works based on the software; export the software or underlying technology in contravention of applicable US and international export laws and regulations; or use the software other than as authorized in connection with use of Product.
- f) **Additional Restrictions Relating To Software And Other Intellectual Property**

In addition to compliance with the Terms of this Warranty, Customers purchasing software or other intellectual property shall comply with any license agreement accompanying such software or other intellectual property. Failure to do so may void this Warranty with respect to such software and/or other intellectual property.

9.3.5 Disclaimer of all Other Warranties

The Warranty set forth in What Is Covered By This Warranty (page 106) are in lieu of all other warranties, express or implied, including but not limited to the implied warranties of merchantability and fitness for a particular purpose.

9.3.6 Limitation of Remedies **

In no event will ProSoft or its Dealer be liable for any special, incidental or consequential damages based on breach of warranty, breach of contract, negligence, strict tort or any other legal theory. Damages that ProSoft or its Dealer will not be responsible for included, but are not limited to: Loss of profits; loss of savings or revenue; loss of use of the product or any associated equipment; loss of data; cost of capital; cost of any substitute equipment, facilities, or services; downtime; the claims of third parties including, customers of the Purchaser; and, injury to property.

** Some areas do not allow time limitations on an implied warranty, or allow the exclusion or limitation of incidental or consequential damages. In such areas, the above limitations may not apply. This Warranty gives you specific legal rights, and you may also have other rights which vary from place to place.

9.3.7 Time Limit for Bringing Suit

Any action for breach of warranty must be commenced within 39 months following shipment of the Product.

9.3.8 No Other Warranties

Unless modified in writing and signed by both parties, this Warranty is understood to be the complete and exclusive agreement between the parties, suspending all oral or written prior agreements and all other communications between the parties relating to the subject matter of this Warranty, including statements made by salesperson. No employee of ProSoft or any other party is authorized to make any warranty in addition to those made in this Warranty. The Customer is warned, therefore, to check this Warranty carefully to see that it correctly reflects those terms that are important to the Customer.

9.3.9 Allocation of Risks

This Warranty allocates the risk of product failure between ProSoft and the Customer. This allocation is recognized by both parties and is reflected in the price of the goods. The Customer acknowledges that it has read this Warranty, understands it, and is bound by its Terms.

9.3.10 Controlling Law and Severability

This Warranty shall be governed by and construed in accordance with the laws of the United States and the domestic laws of the State of California, without reference to its conflicts of law provisions. If for any reason a court of competent jurisdiction finds any provisions of this Warranty, or a portion thereof, to be unenforceable, that provision shall be enforced to the maximum extent permissible and the remainder of this Warranty shall remain in full force and effect. Any cause of action with respect to the Product or Services must be instituted in a court of competent jurisdiction in the State of California.

Index

[

[Backplane Configuration] • 53
 [Radio Configuration] • 54
 [RADIO PWP Exchanges] • 57
 [Radio PWP Multicast Group List] • 61
 [Radio SNTP Client] • 55

A

Add the PTQ Module to the Project • 18, 37
 Adding a Location • 52
 Adding a Module • 50
 Adding a Project • 49
 All Product Returns: • 104
 Allocation of Risks • 109

B

Backplane Data Transfer • 71, 93
 Block 2000 C/P Status Data Format • 97
 Block 2000 Request • 96
 Block 2000 Response • 96
 Block 9250 Request Block (General Status) • 97
 Block 9250 Response Block (General Status) • 97
 Build the Project • 39

C

C/P Status Data (Block 2000) • 96
 Cast Type • 57
 Channel • 63
 Clearing a Fault Condition • 85
 Command Control Blocks • 96
 Comment Entries • 52
 Configuring the Processor with Concept • 13
 Configuring the Processor with ProWORX • 31
 Configuring the Processor with UnityPro XL • 35
 Connect the PC to the ProTalk Configuration/Debug Port • 44
 Connect Your PC to the Processor • 40
 Connecting to the Processor with TCP/IP • 41
 Continuously Monitoring Radio Status • 80
 Controlling Law and Severability • 109
 Create a New Project • 15, 35
 Create_IBSS • 62
 CS Major, CS Minor • 60

D

Database Register • 56
 Database View Menu • 77
 DB Reg • 58
 Diagnostics and Troubleshooting • 7, 71
 Disclaimer of all Other Warranties • 108
 Disclaimer Regarding High Risk Activities • 107
 Displaying the Current Page of Registers Again • 78

Download the Project to the Processor • 23, 42

E

Enable_Encryption • 63
 Exch ID • 59
 Exch Type • 57
 Exchange Configuration Form • 101
 Exiting the Program • 77

F

Failure Flag Count • 54
 Functional Overview • 7, 89
 Functional Specifications • 88

G

General Concepts • 92
 General Specifications • 87
 General Status (Block 9250) • 97
 Going Ahead Two Pages of Data • 83
 Going Back Two Pages of Data • 83
 Guide to the PTQ-WA-PWP User Manual • 7

H

Hardware and Software Requirements • 9
 Hardware Specifications • 88
 How to Contact Us
 Technical Support • 103, 104

I

Important Installation Instructions
 Radio Modules • 3
 Information for Concept Version 2.6 Users • 14
 Information for ProTalk® Product Users • 2
 Install ProSoft Configuration Builder Software • 11
 Install the ProTalk Module in the Quantum Rack • 43
 Installing MDC Configuration Files • 14
 Intellectual Property Indemnity • 107
 IP Address • 59

K

Keystrokes • 74

L

LED Status Indicators • 7, 83
 Limitation of Remedies ** • 108
 LIMITED WARRANTY • 105

M

Main Logic Loop • 93
 Main Menu • 74
 Module Entries • 51
 Moving Back Through 5 Pages of Registers • 78

N

Navigation • 73
 Network Menu • 76, 80
 Network_Name_(SSID) • 62
 No Other Warranties • 109

Normal Data Transfer • 95
NTP Server IP Address • 56

O

Opening the Database Menu • 75
Opening the Map Data Menu • 76
Opening the Network Menu • 76
Opening the Producer/Consumer List Menu • 81
Opening the PWP Menu • 76
Opening the Radio Menu • 75
Opening the Status Data Menu • 82

P

P/C Time • 58
PC and PC Software • 10
Pinouts • 2
Printing a Configuration File • 52
Procedures for Return of Units Out of Warranty: • 104
Procedures for Return of Units Under Warranty: • 104
Product Specifications • 7, 87
ProSoft Configuration Builder • 47
ProTalk Module Carton Contents • 9
Purchasing Warranty Extension: • 105
PWP Consumer • 92
PWP Error/Status Data • 100
PWP Menu • 81
PWP Producer • 91

Q

Quantum / Unity Hardware • 10
Quantum / Unity Processor Not in Run • 93

R

Radio Ethernet Configuration • 61
Radio Menu • 79
Radio PWP Exchange Command List Example • 61
Radio PWP Producer/Consumer List Menu • 82
Radio_Default_Gateway • 62
Radio_IP • 62
Radio_Subnet_Mask • 62
Read Block • 95
Read Register Count • 53
Read Register Start • 53
Reading Status Data from the Module • 71
Redisplaying the Current Page • 83
Redisplaying the Menu • 74, 82
Reference • 7, 87
Reg Count • 58
Required Hardware • 71
Resetting diagnostic data • 75
Return Material Authorization (RMA) Policies and Conditions • 104
Returning to the Main Menu • 79, 80, 81, 82
Returning to the Previous Menu • 83
RF LEDs • 7, 84
RS-232 Configuration/Debug Port • 99
Rules for CS Validation • 60

S

Save and Download the Configuration File to the 6104-WA-PDPM • 67
Save and Download the Configuration File to the PTQ-WA-PWP • 65
Set Module Parameters • 51
Set up Data Memory in Project • 20, 46
Set Up the Project • 48
Setting Up the ProTalk Module • 43
Signal LED 1, 2, 3, 4 • 54
Skipping 500 Registers of Data • 78
Software Reset (Block 9998/9999) • 99
Start Here • 7, 9
Station_Name • 63
Support, Service & Warranty • 7, 103
Swap Code • 58

T

The Configuration/Debug Menu • 72
Time Limit for Bringing Suit • 108
Time Zone • 56
Transferring the Configuration File from PTQ module to PC • 75
Transferring WATTCP.CFG to the module • 80
Transferring WATTCP.CFG to the PC • 81
Transmit Rate • 55, 57, 59
Transmit_WEP_Key • 64
Troubleshooting • 85

U

Underlying Protocol Requirements and Constraints • 90
Use Daylight Savings Time • 56
Using the Diagnostic Window in ProSoft Configuration Builder • 72

V

Verify Communication Between the Processor and the Module • 7, 46
Verify Data Exchange • 7, 68
Verify Radio Communications • 7, 65
Verify Successful Download • 26
Viewing Data in ASCII (Text) Format • 78
Viewing Data in Decimal Format • 78
Viewing Data in Floating Point Format • 78
Viewing Data in Hexadecimal Format • 78
Viewing Module Configuration • 75
Viewing Radio Configuration • 79
Viewing Radio Status • 79
Viewing Register Pages • 77
Viewing SNMP Status • 76
Viewing the Multicast Group List • 82
Viewing the Next 100 Registers of Data • 78
Viewing the Next Page of Data • 83
Viewing the Previous 100 Registers of Data • 78
Viewing the Previous Page of Data • 83
Viewing the WATTCP.CFG file on the module • 81
Viewing Version Information • 75

W

- Warm Booting the Module • 76
- Warnings • 2
- WEP Key Rollover • 55
- WEP_Key_1 to WEP_Key_4 • 63
- What Is Covered By This Warranty • 106, 108
- What Is Not Covered By This Warranty • 106
- Write Block • 96
- Write Register Count • 53
- Write Register Start • 53

Y

- Your Feedback Please • 4